



# RENTAFILL

FILLING EQUIPMENT HIRE

U11/6 Leighton Place  
Hornsby, NSW, 2077  
ph: 02 9987 1871

BenchMATE manual

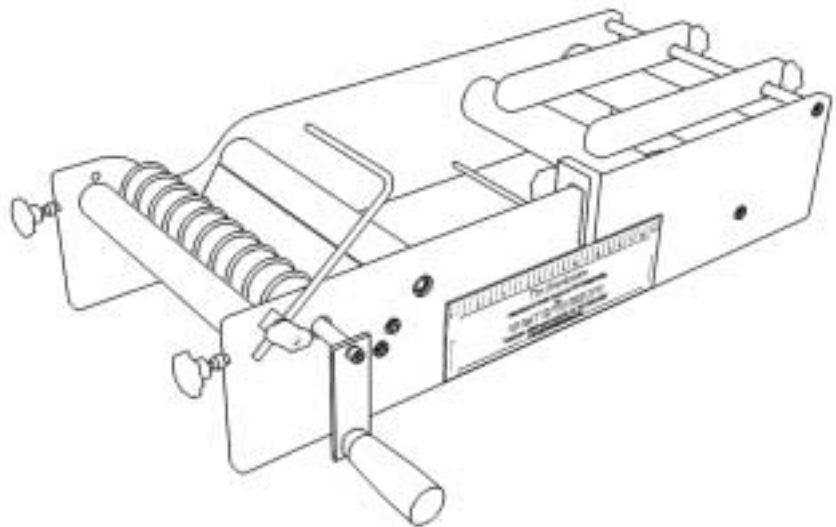

# LABEL SPECIFICATIONS

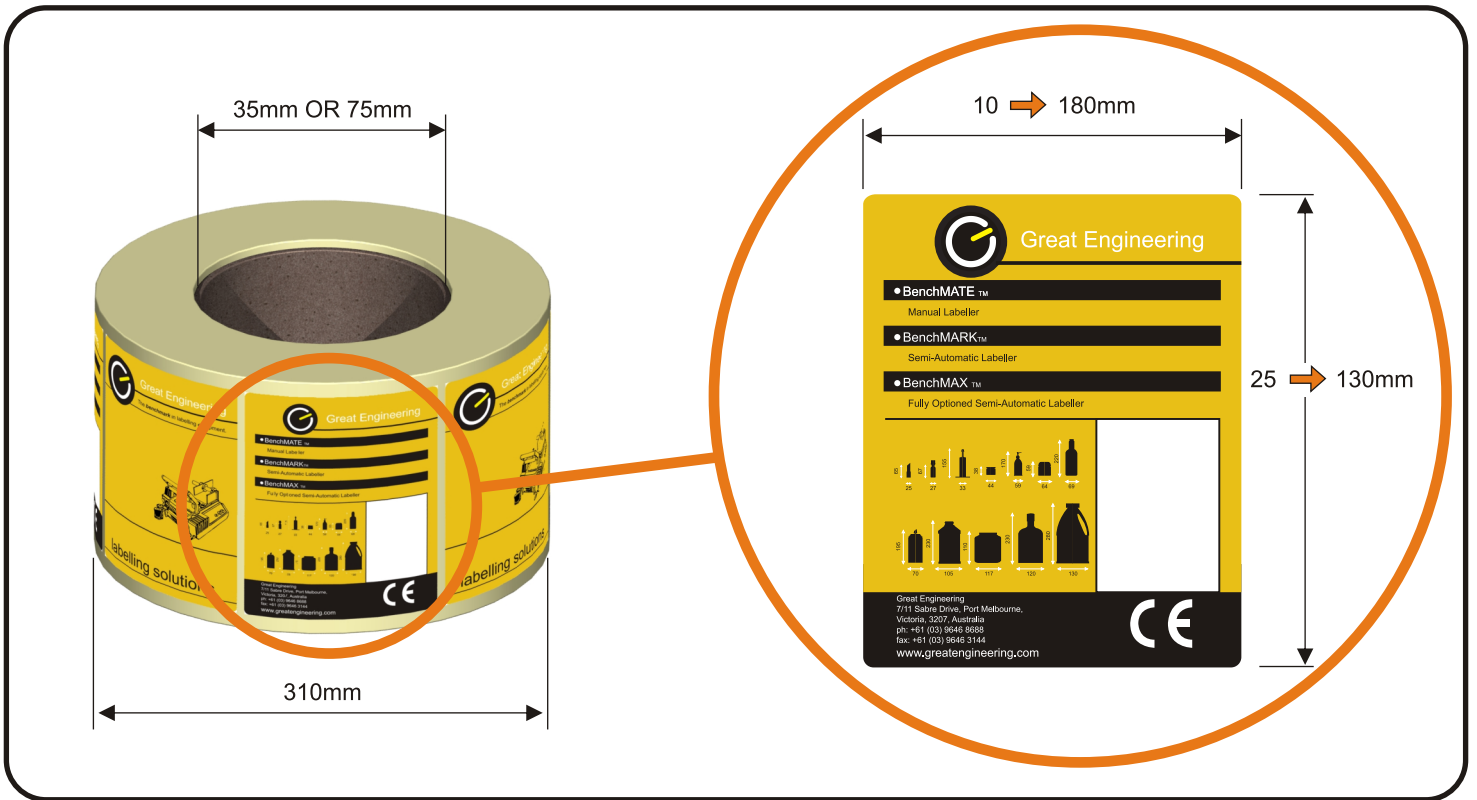

## ROLL TYPE (A)

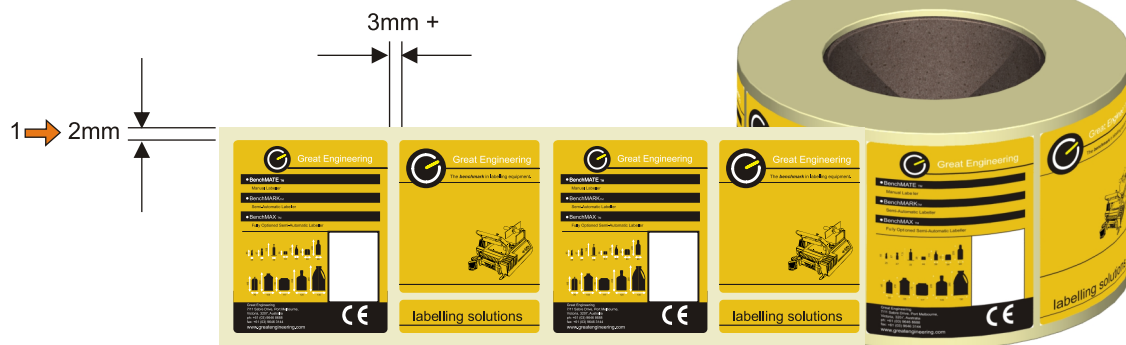

OR

## ROLL TYPE (B)

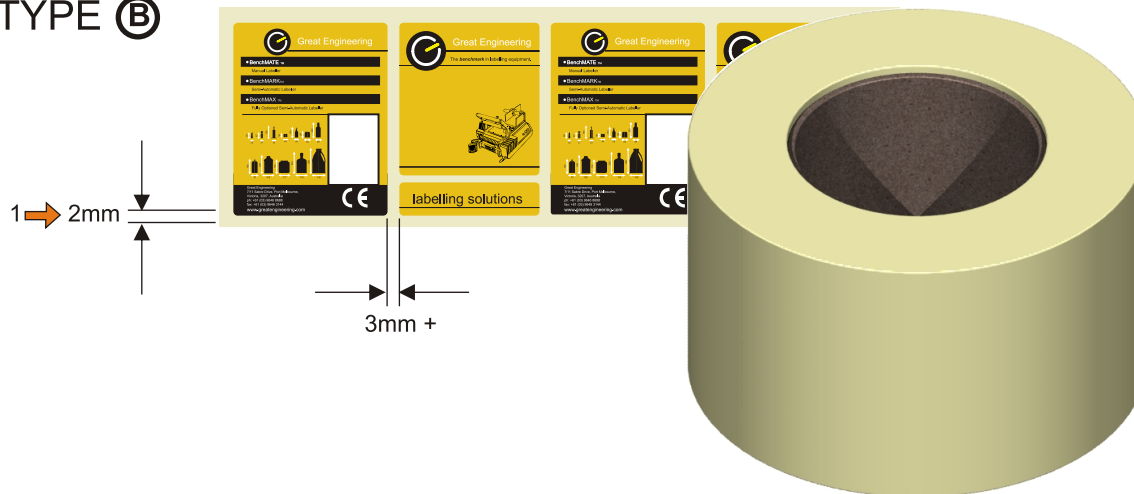

# COMPONENTS & SET-UP

PACKING LIST ITEMS:

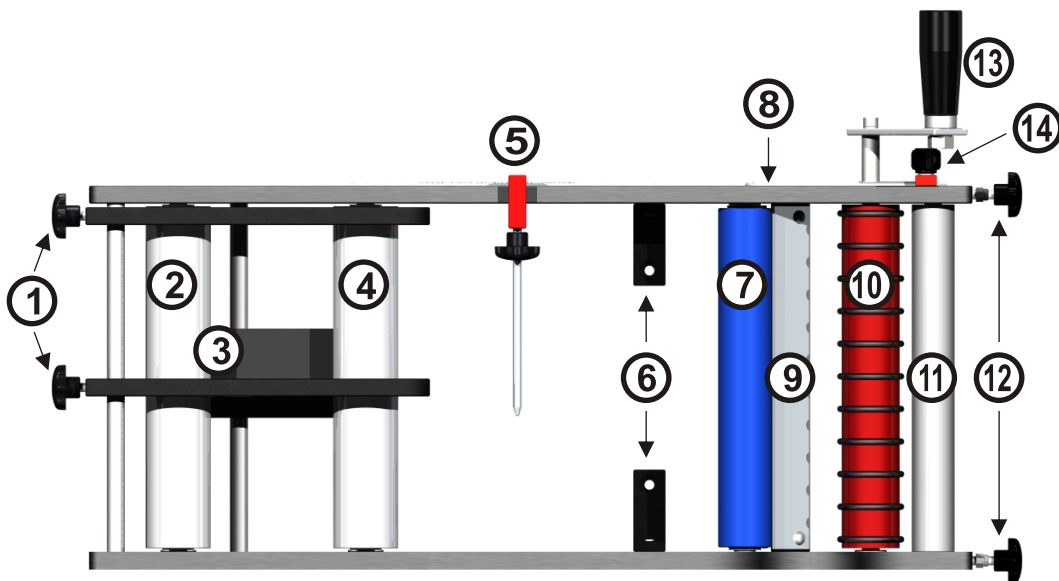
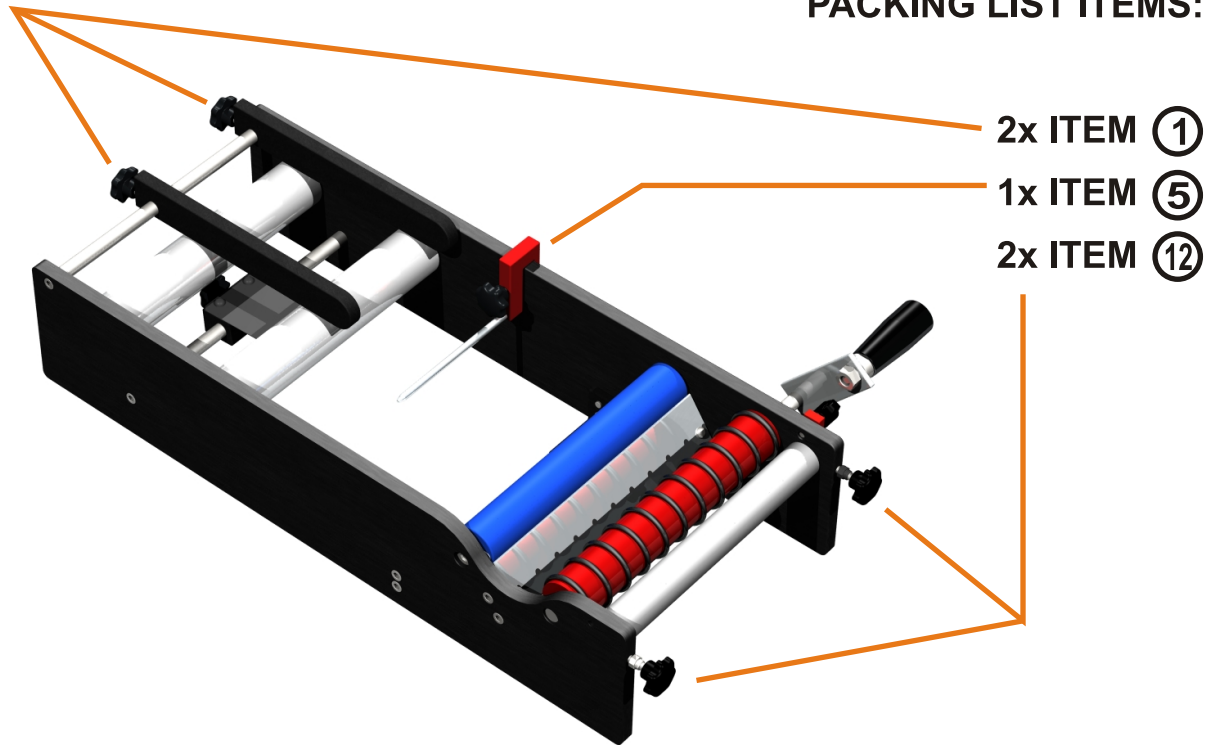

TOP VIEW

① Guide Arm Thumbscrews	⑧ Indicator 2
② Plastic Roller 1	⑨ Peel Plate
③ Tensioner	⑩ Red Roller with O Rings
④ Plastic Roller 2	⑪ Plastic Roller 3
⑤ Indicator 1	⑫ Thumb Screws with Locnuts
⑥ Clamp Points	⑬ Handle
⑦ Blue Rubber Roller	⑭ Indicator 2 Lock-off

1

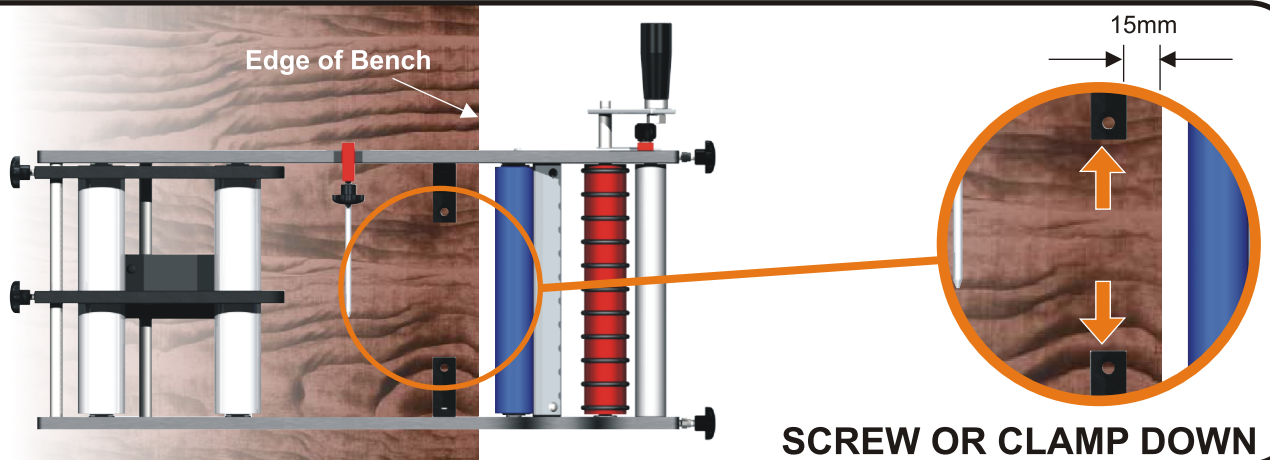

SCREW OR CLAMP DOWN

2

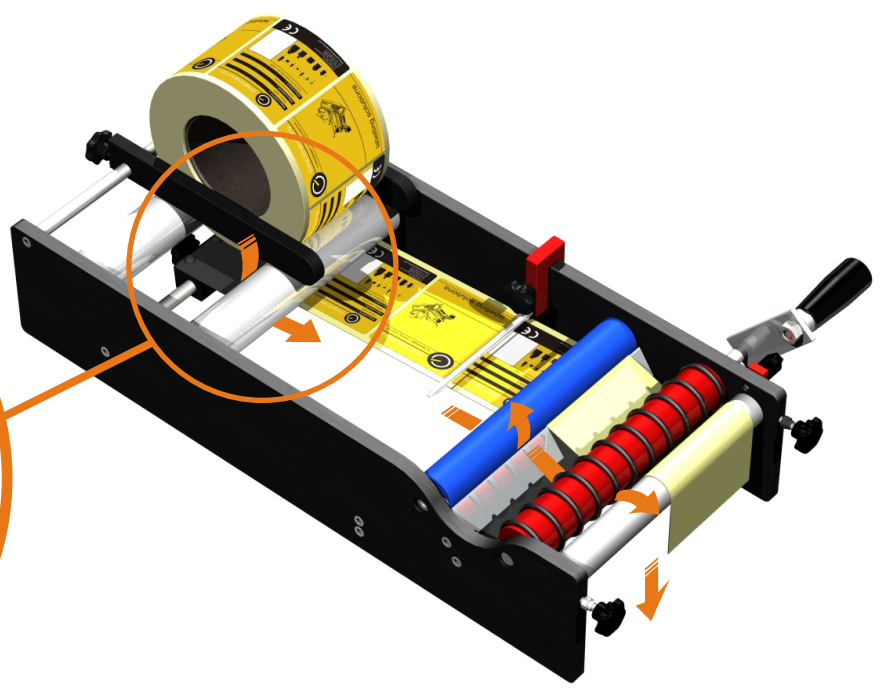
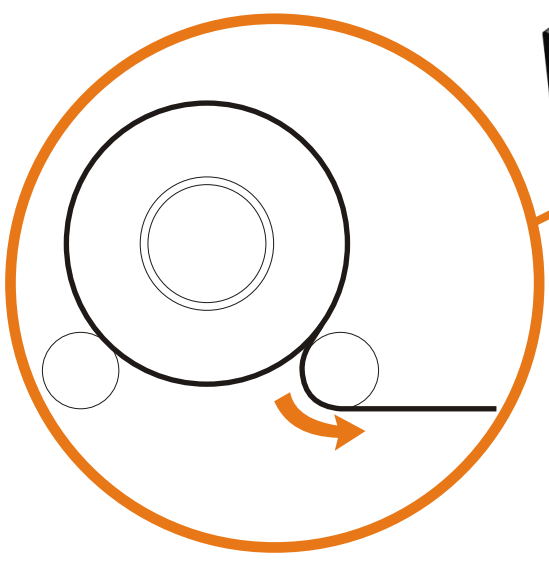

OR

THREAD LABELS

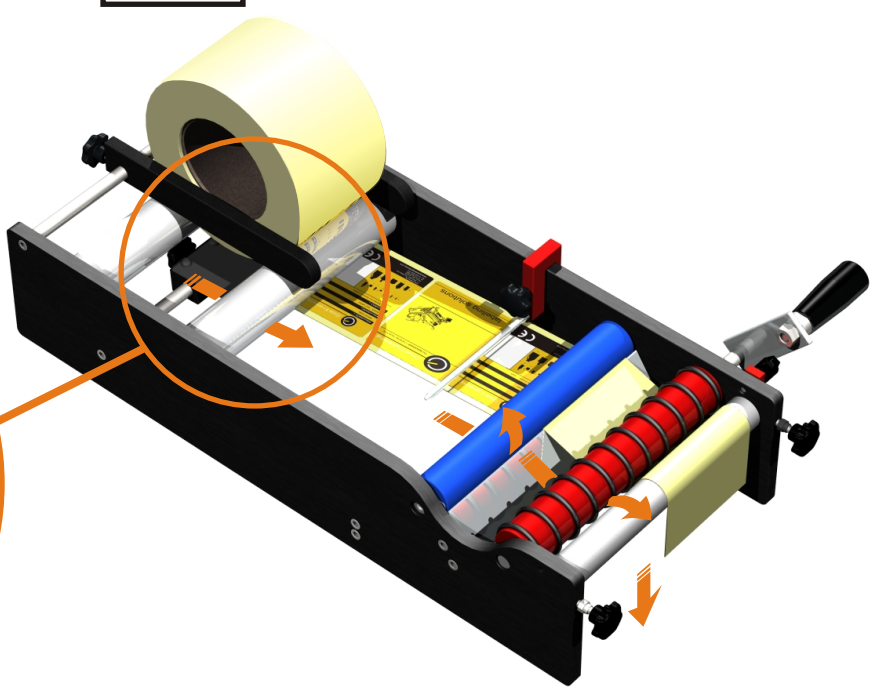
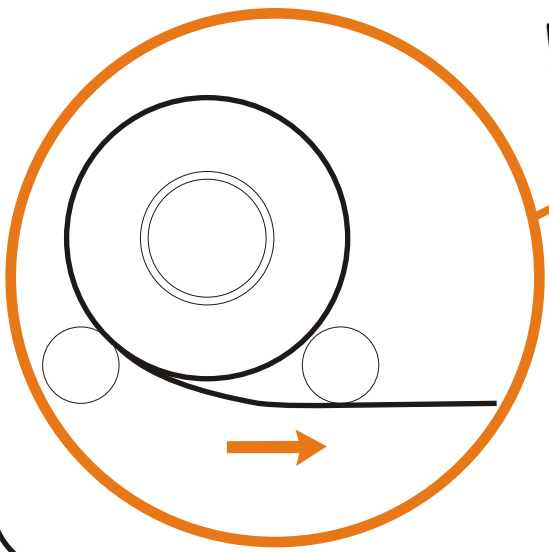

THREAD LABELS



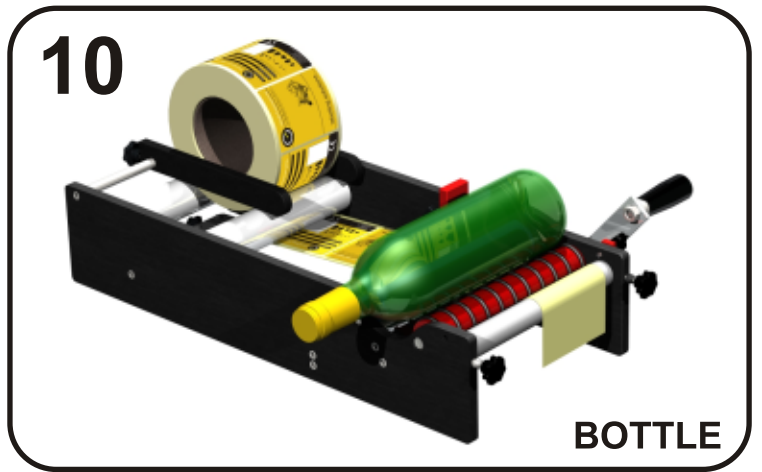
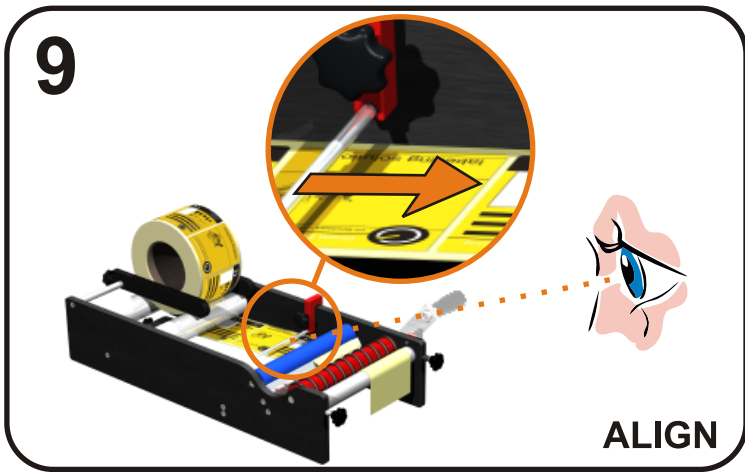
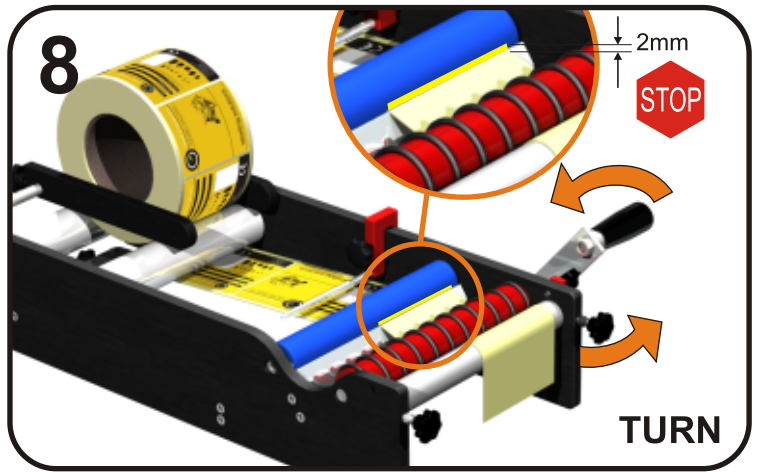
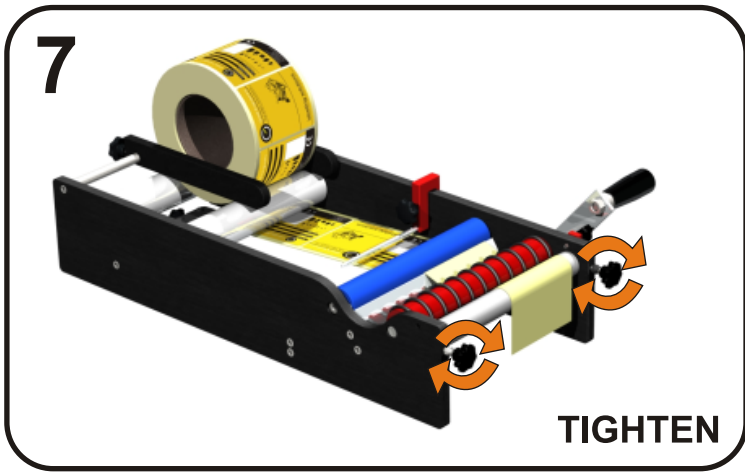
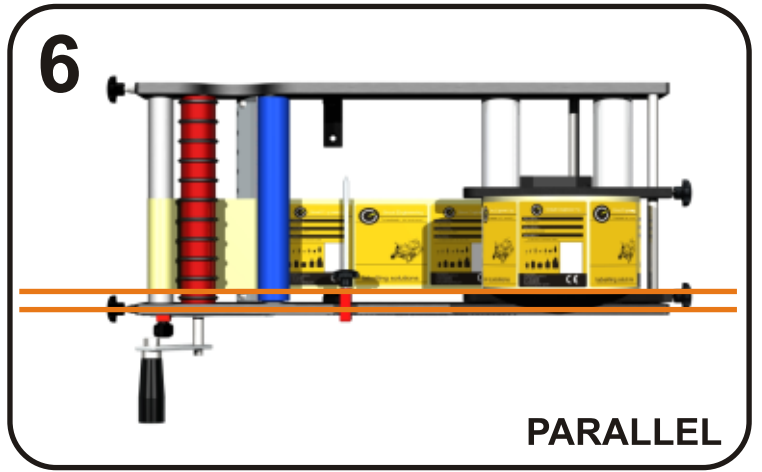
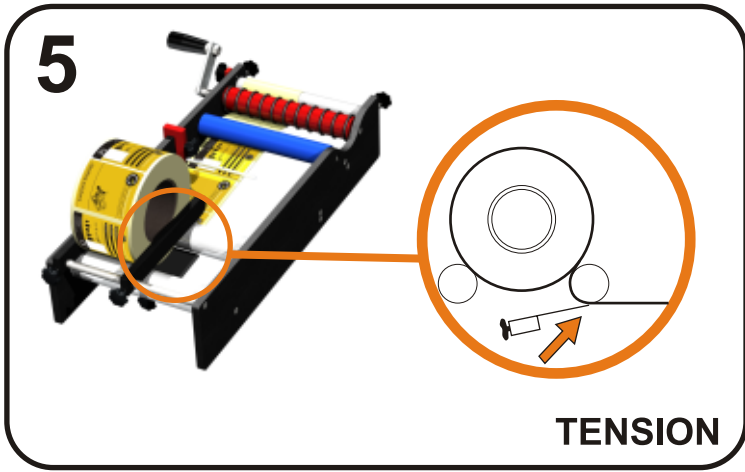
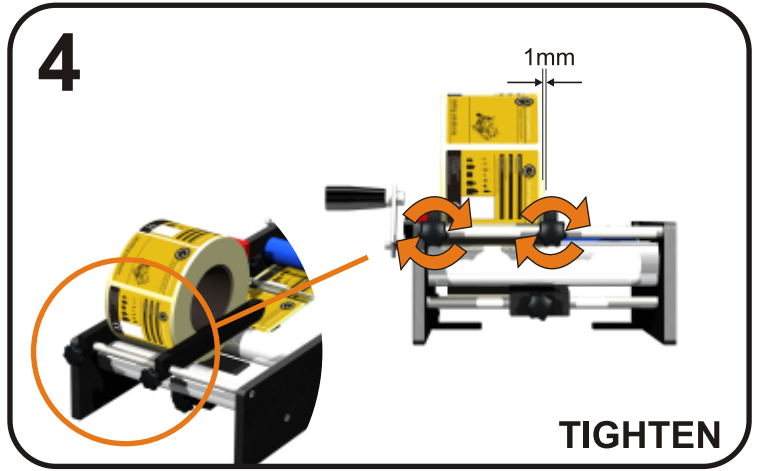
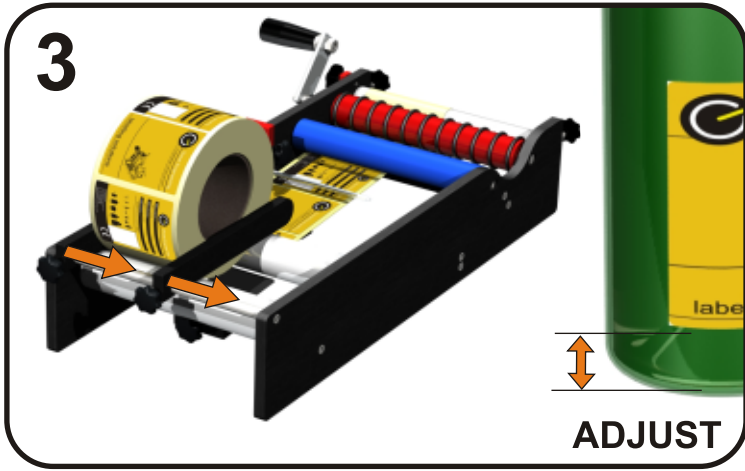

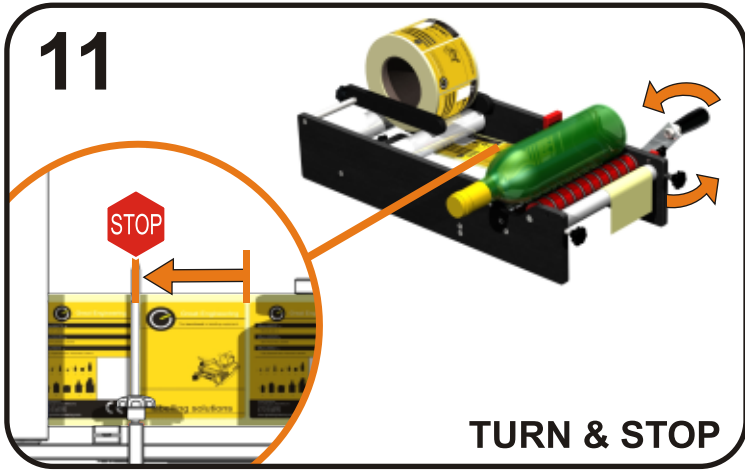

## APPLYING 2ND LABEL - DISTANCED

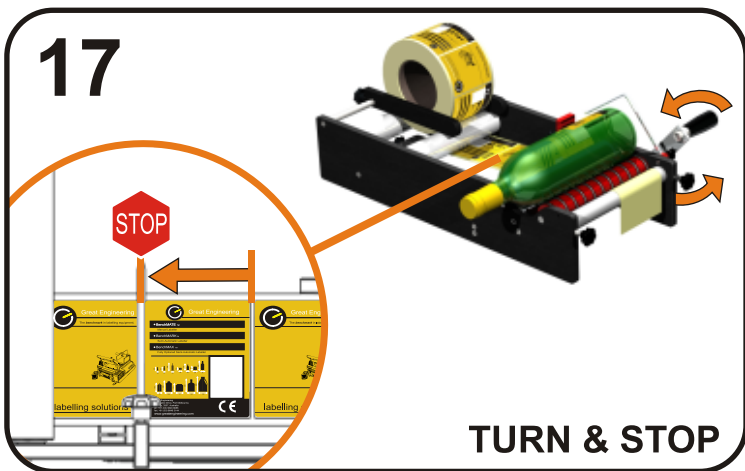
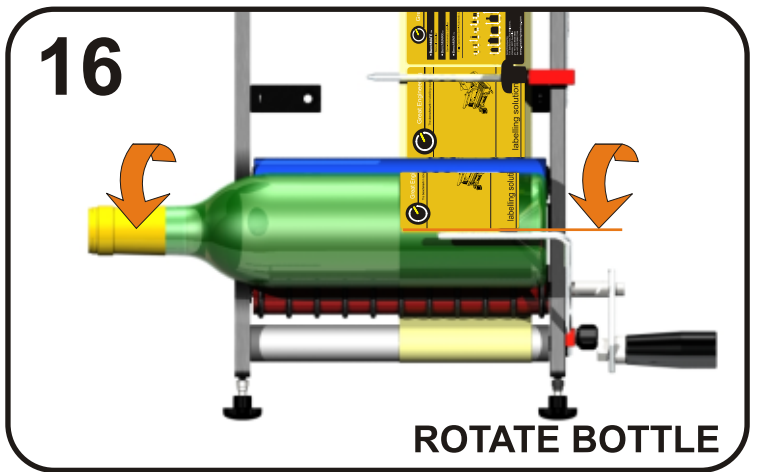
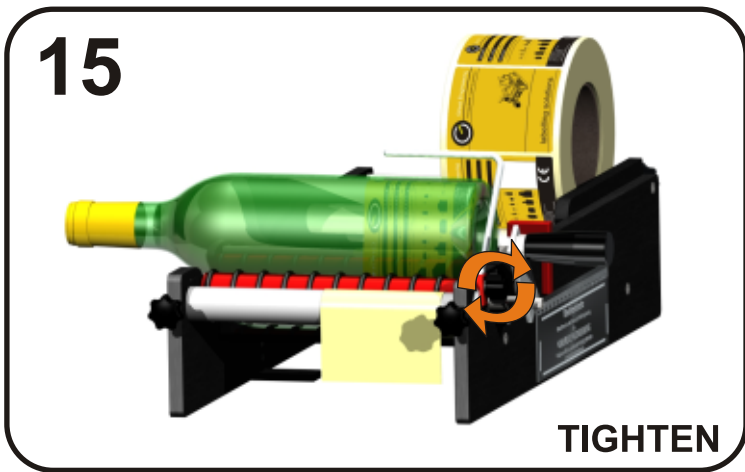
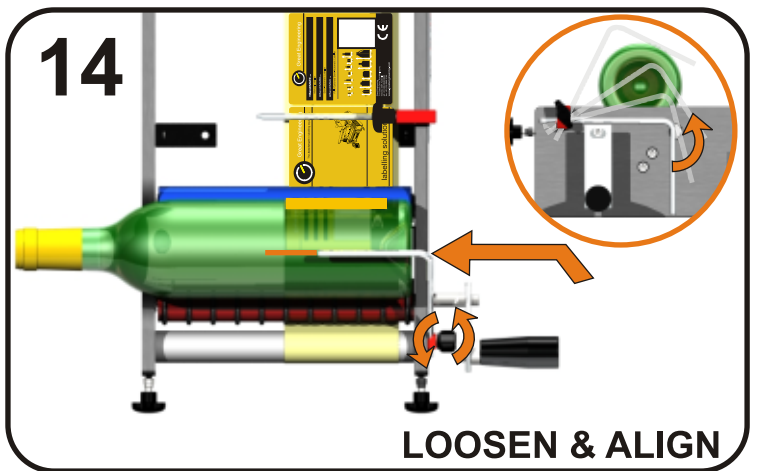
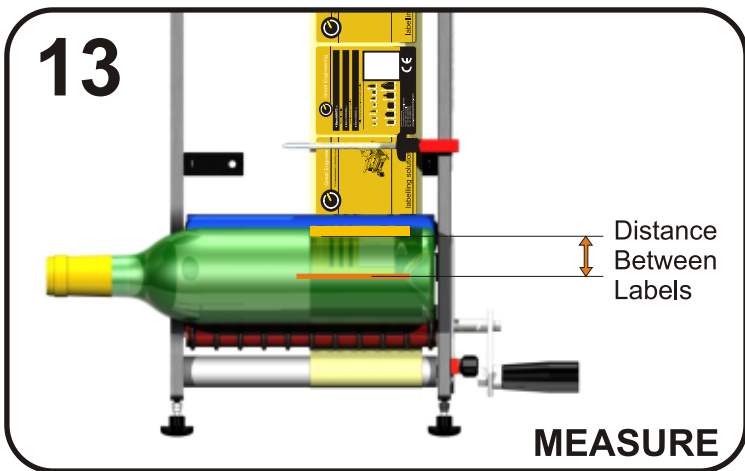

# BOTTLES WITH RECESSES

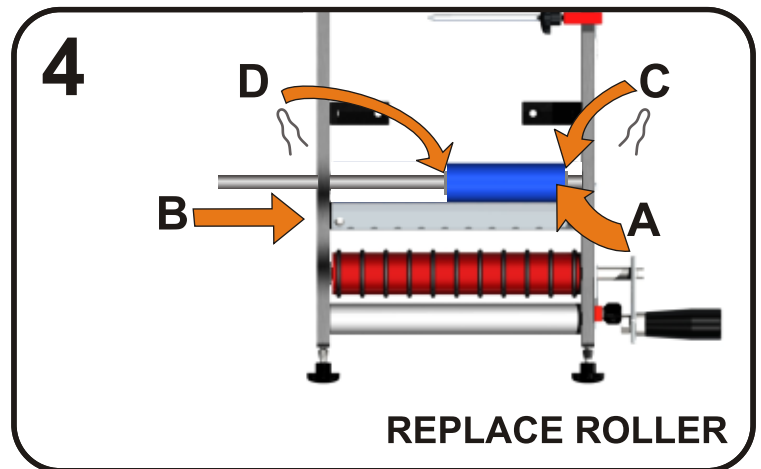
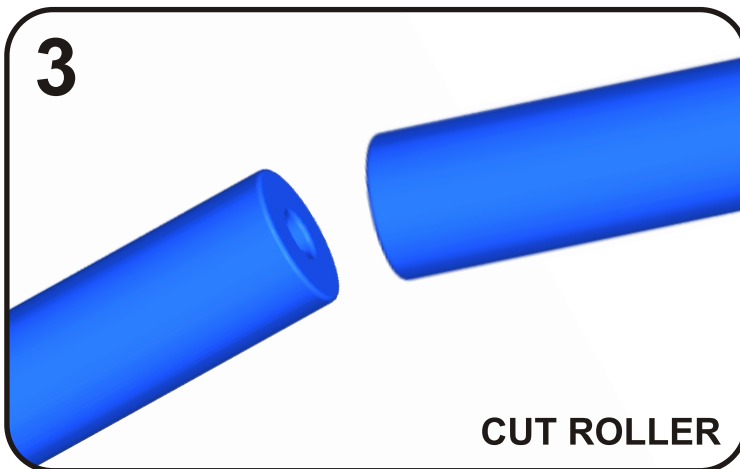
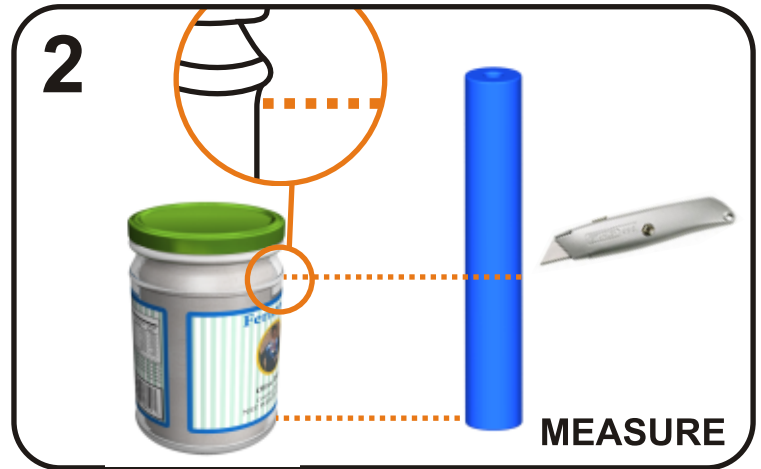
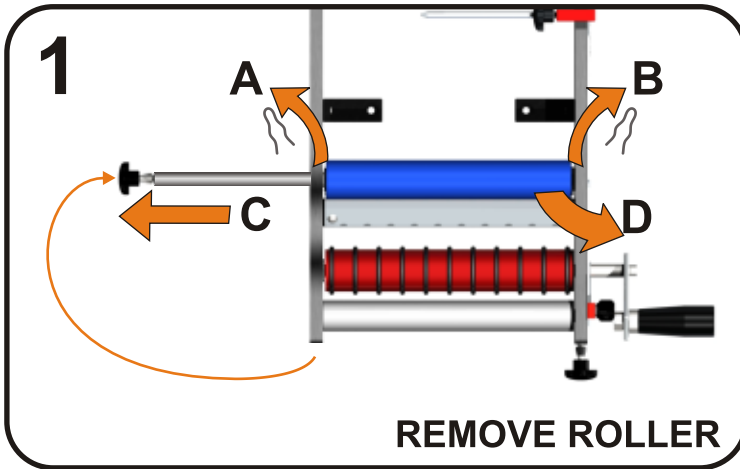

# MAINTENANCE

## REPLACING 'O' RINGS

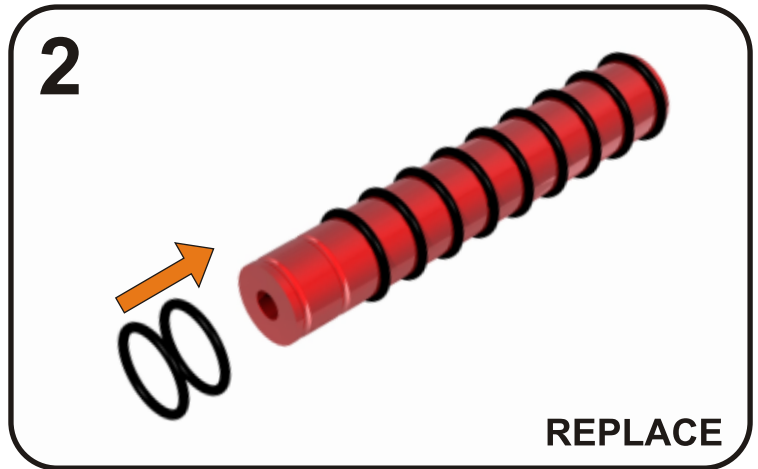
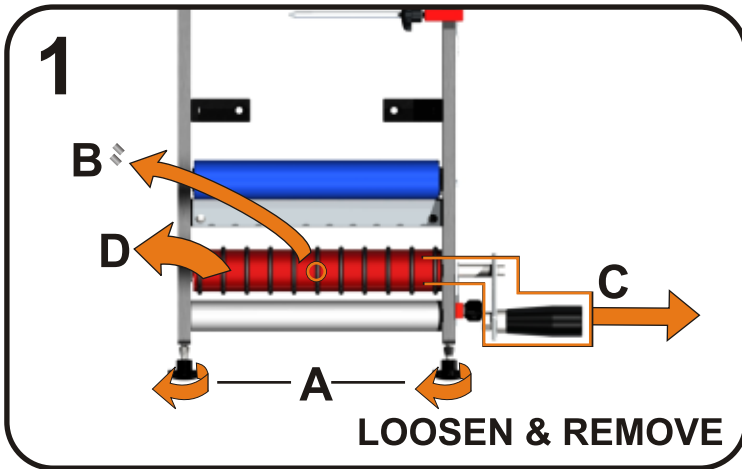

## WEAR MAINTENANCE

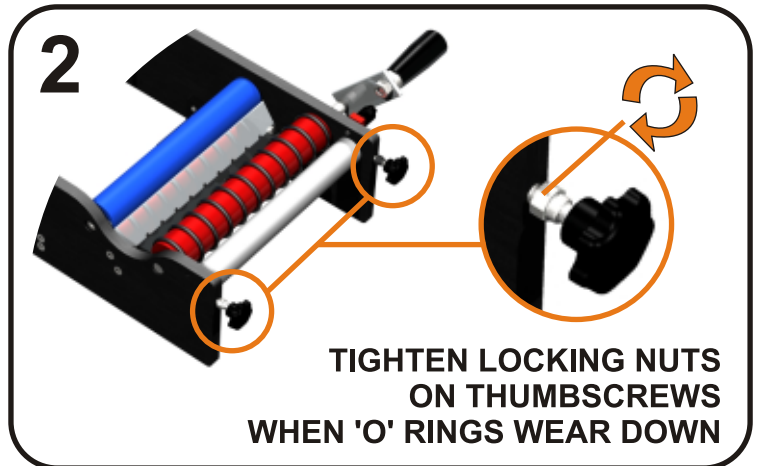
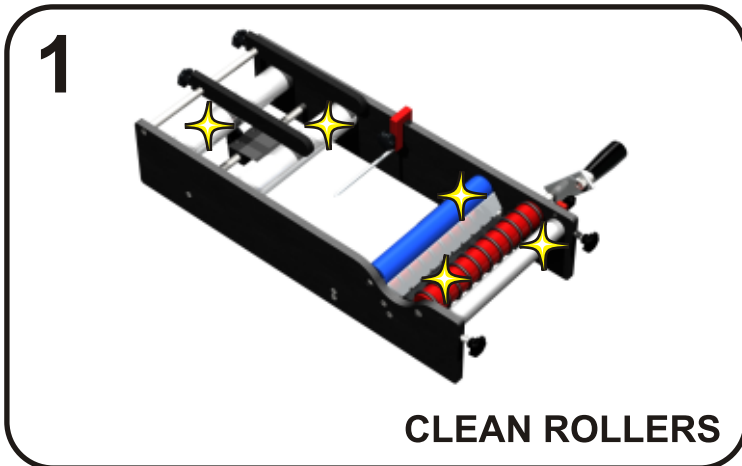

**PLEASE NOTE:** *Cutting rollers on Hire machines will result in the Hirer having to purchase the cut rollers - please ensure to contact RENTAFILL for pricing prior to cutting.*