



RENTAFILL







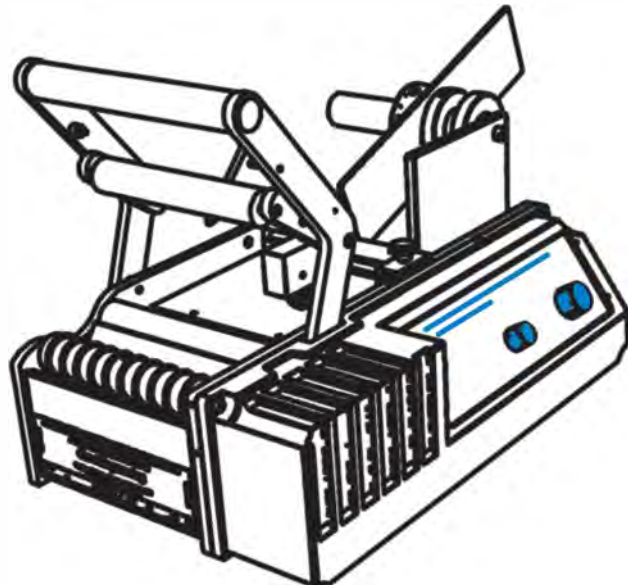
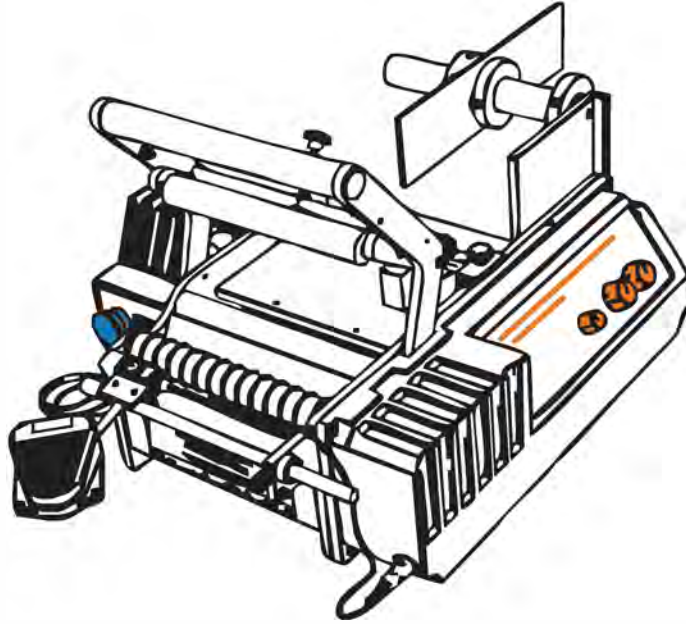



FILLING EQUIPMENT HIRE

11/6 Leighton Place, Hornsby,
NSW, 2077, Australia
Ph: 02 9987 1871
www.rentafill.com.au

BenchMAX and BenchMARK manual



CONTENTS:

	3
	4
	7
	8
	9
	10
	13
	14
	16
	17
	20

LABEL SPECIFICATIONS



35mm (1 3/8") OR 76mm (3")

MIN 25mm (1")
MAX 225mm (9")

MIN 310mm (12")

Great Engineering

BenchMATE™
Manual Labeller

BenchMARK™
Semi-Automatic Labeller

BenchMAX™
Fully Optional Semi-Automatic Labeller

BenchMARK™
MIN 10mm (3/8")
MAX 180mm (7")

BenchMAX™
MIN 10mm (3/8")
MAX 230mm (9")

CE

Great Engineering
271 Borch Drive, Port Melbourne,
Victoria, 3207 Australia
Ph: +61 (0) 39588 8888
Fax: +61 (0) 39588 2144
www.greatengineering.com

MIN 3mm (1/8")

MIN 1mm (1/32")
MAX 2mm (1/8")

labelling solutions

labelling solutions

labelling solutions

labelling solutions

labelling solutions

CONTAINERS **GLI**

Small Container Adaptor range

Larger containers

11 25 27 33 44 59 64 69 70 105 117 120 130

47 65 67 155 38 170 59 220 195 230 110 230 280

Video available at <http://youtu.be/FZDGScvkRcA>

THREADING LABELS

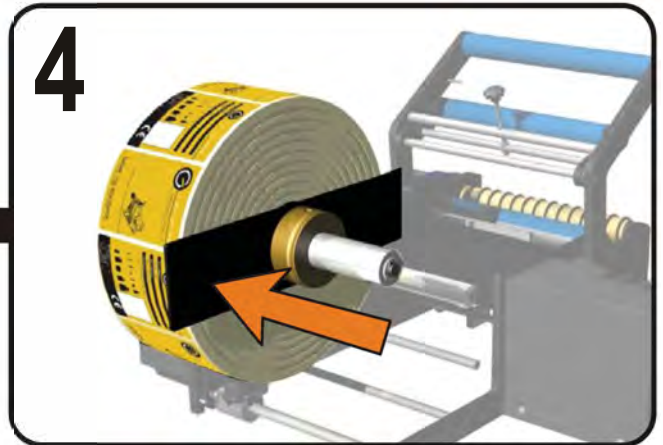
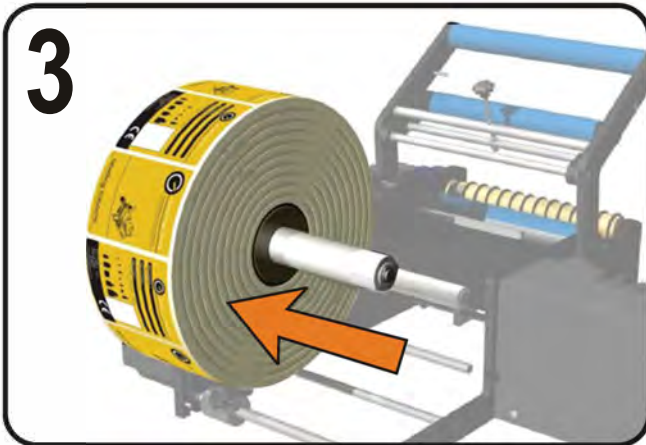
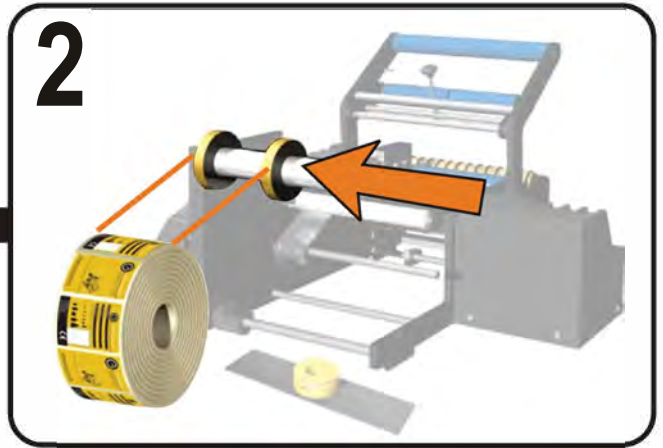
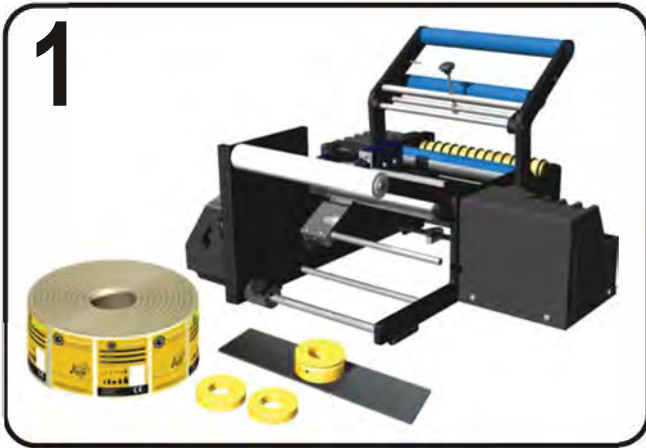
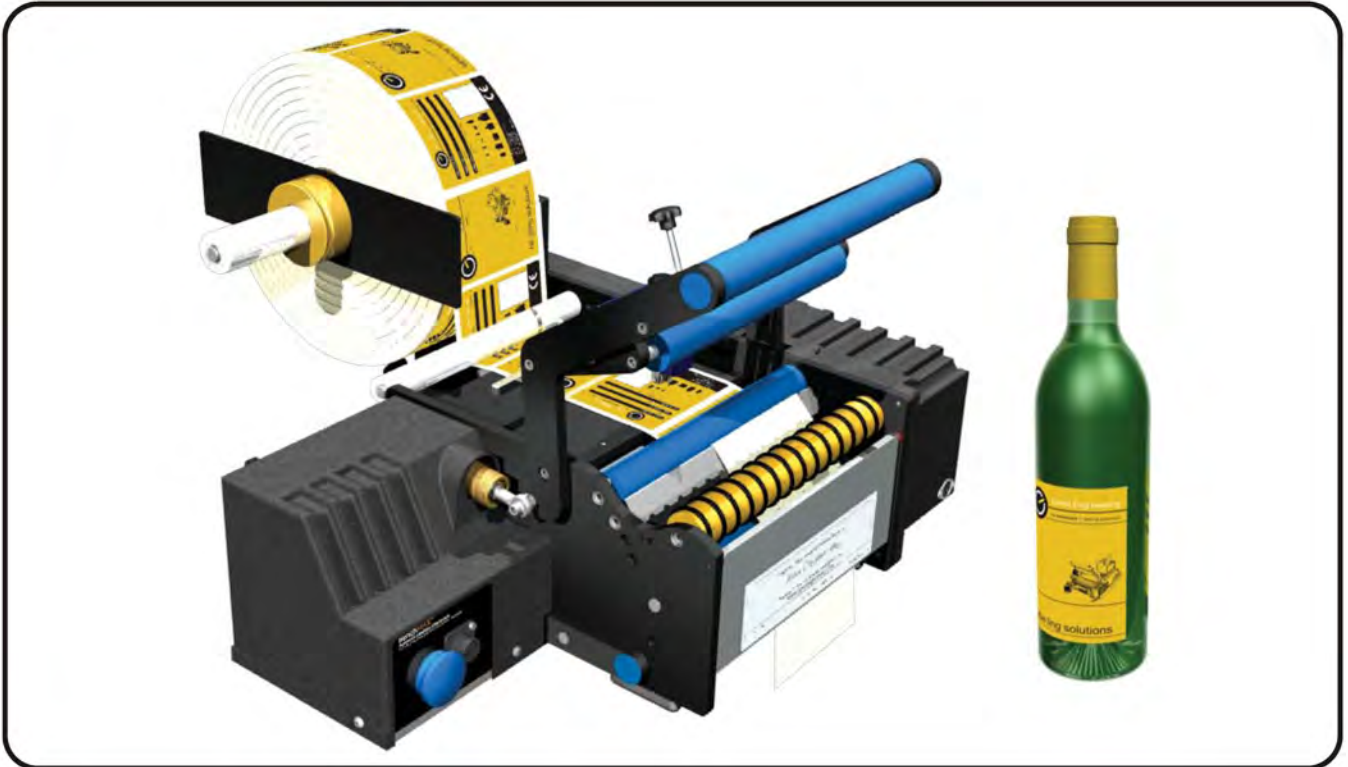

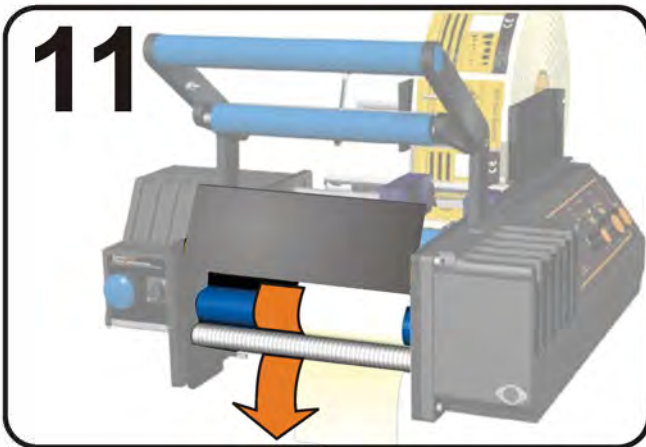
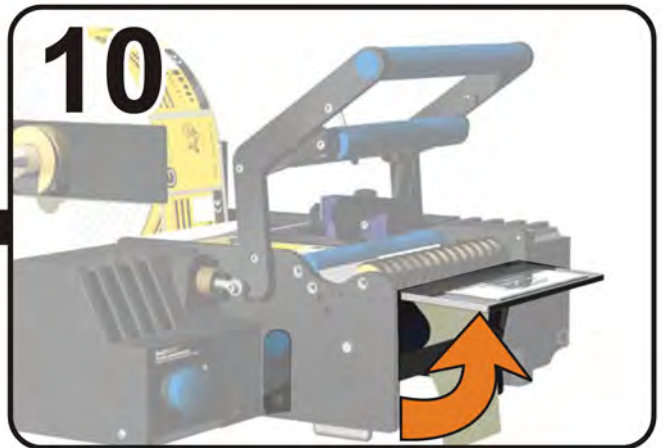
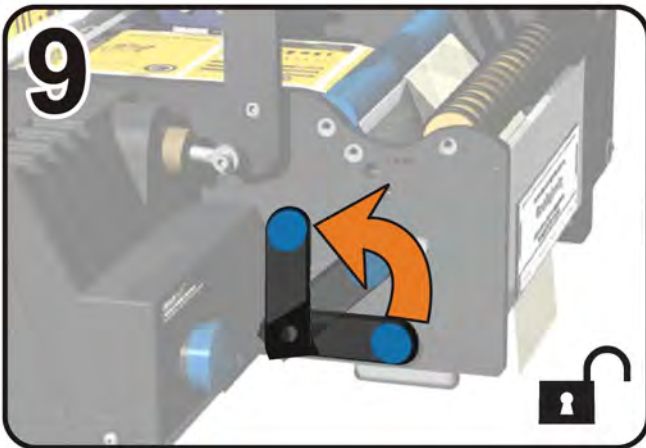
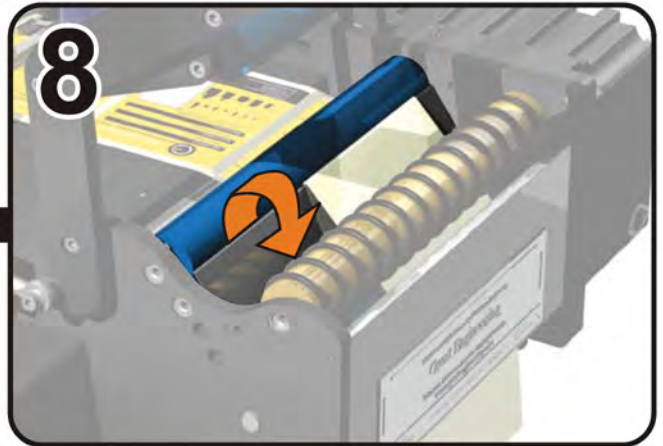
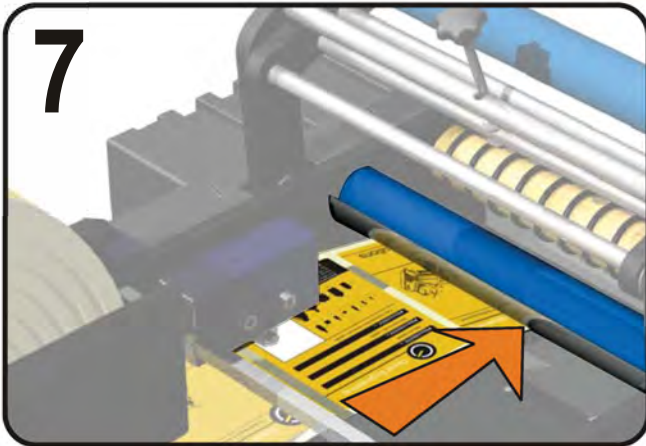
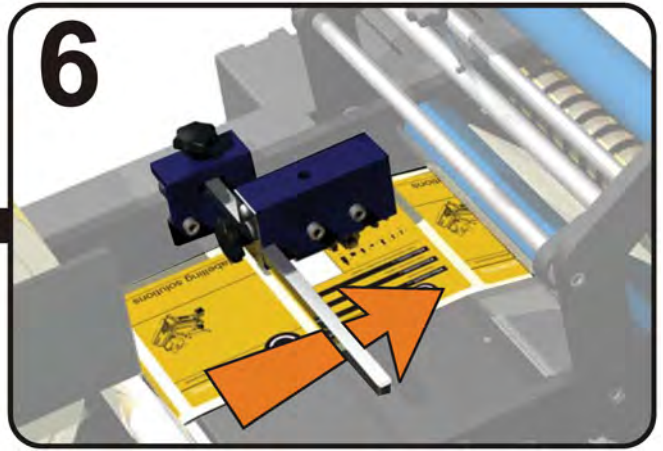
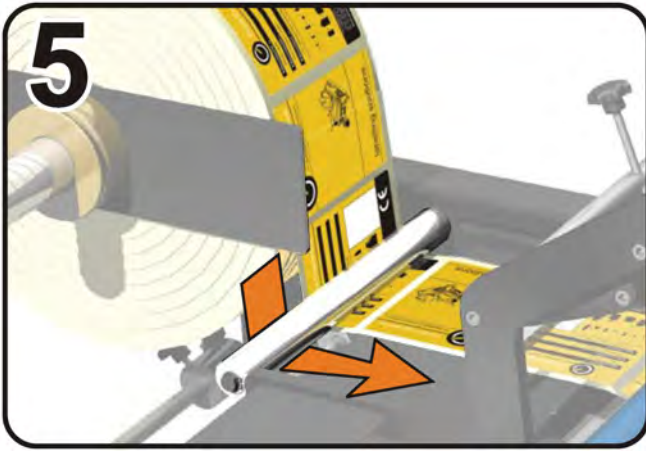

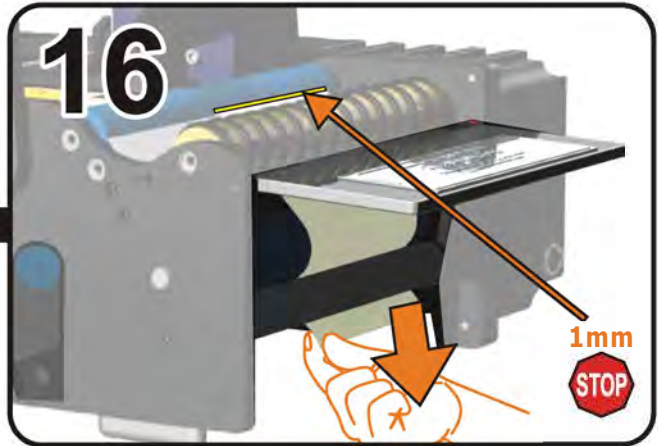
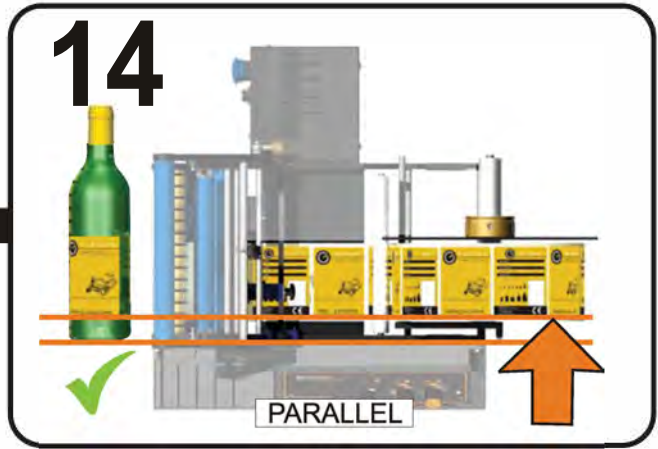
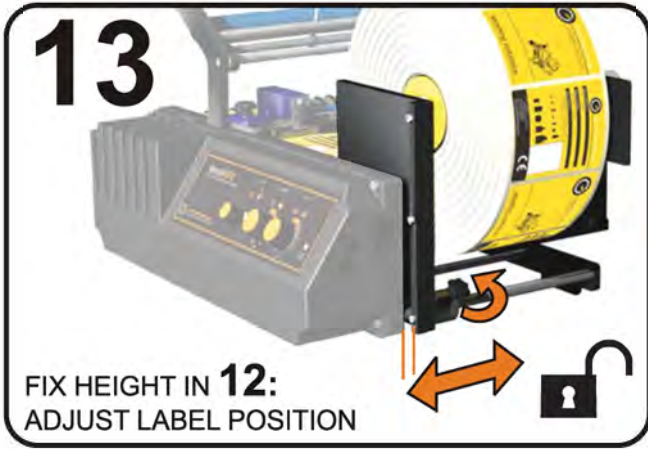

SETTING TENSIONER

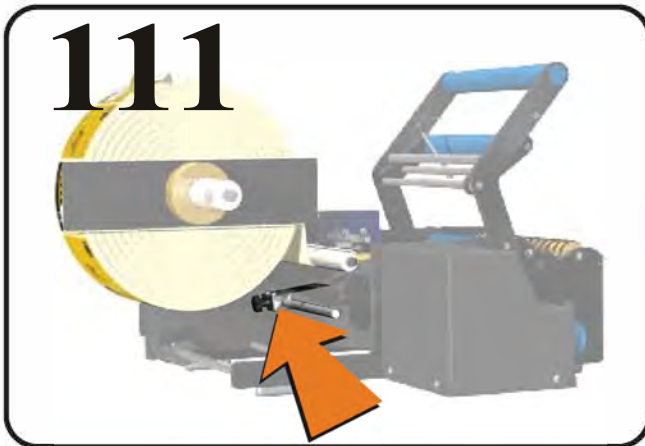

SETTING LABEL SENSOR

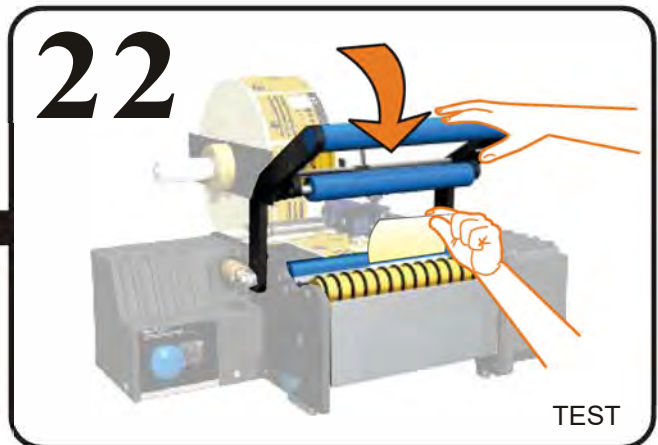
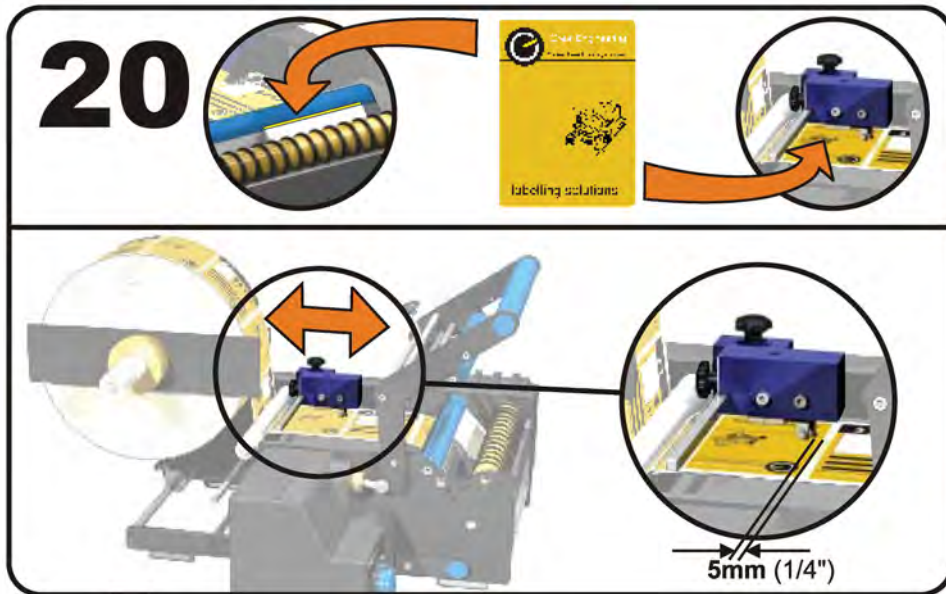

APPLYING 2 LABELS

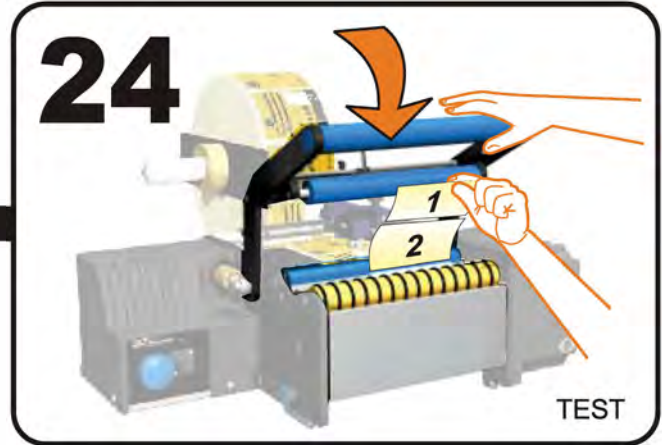

POSITIONING RUB DOWN ROLLER

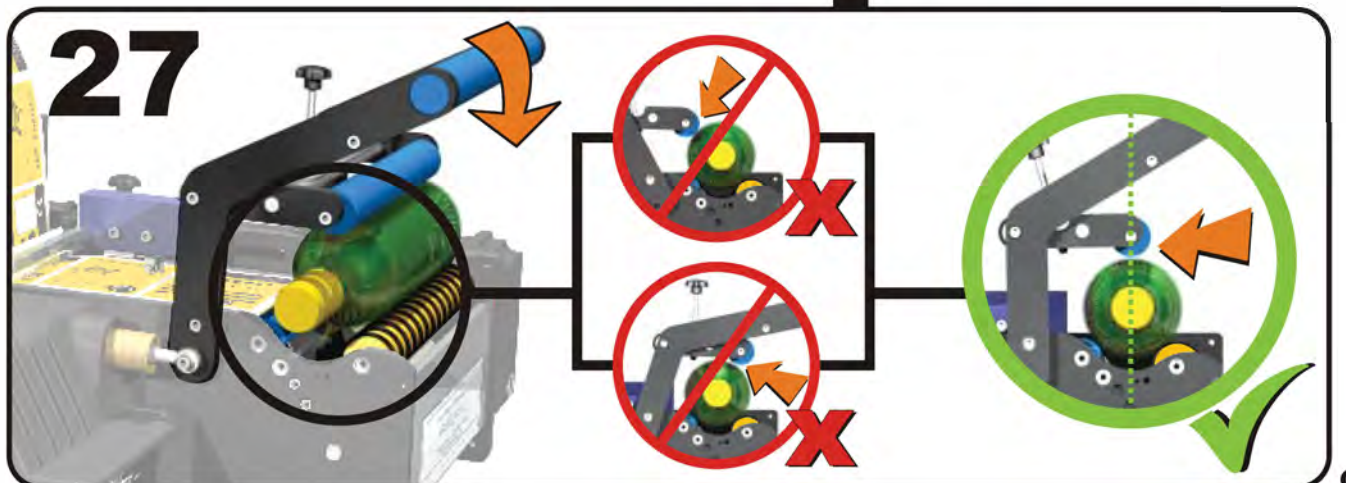
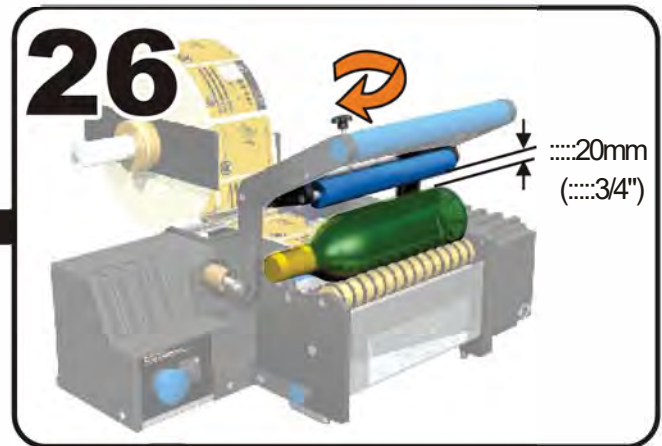

CONTAINERS WITH RECESSES

I, I

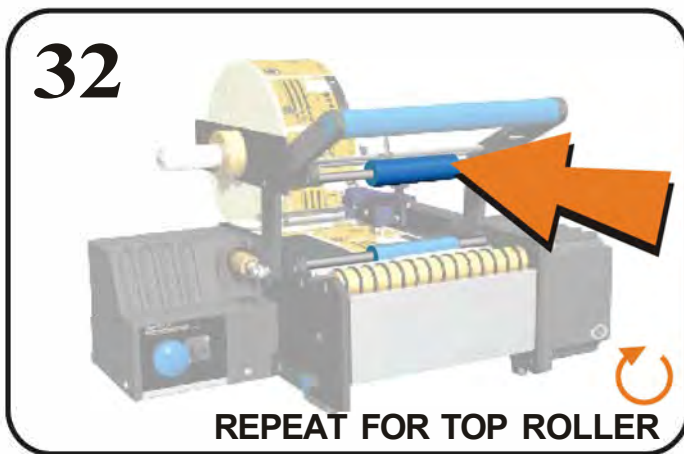
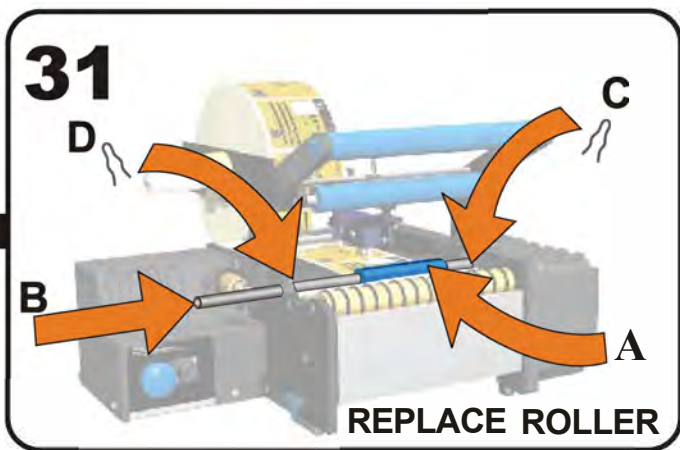
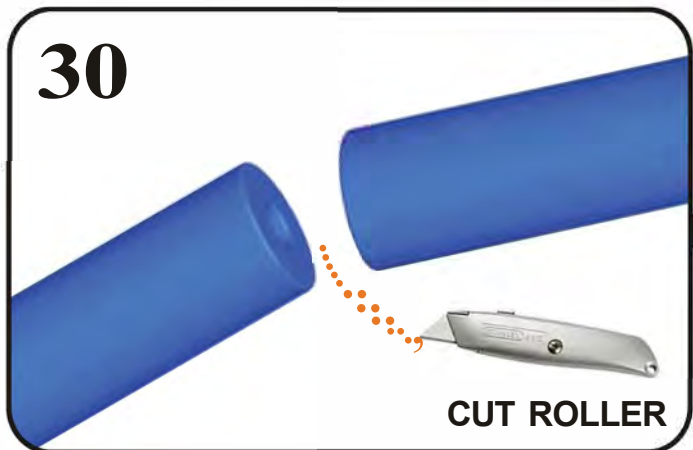
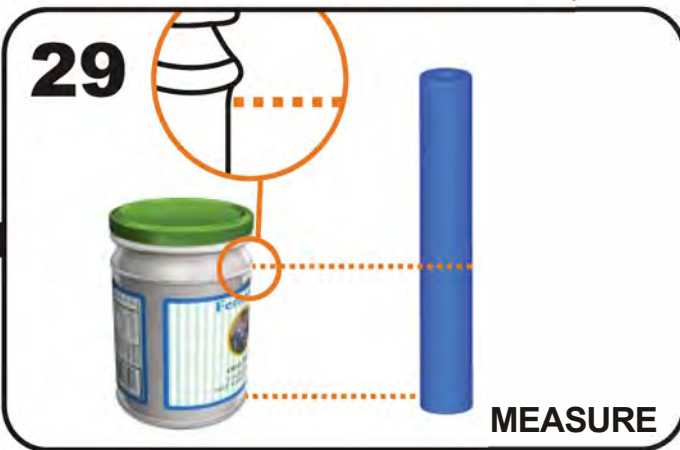
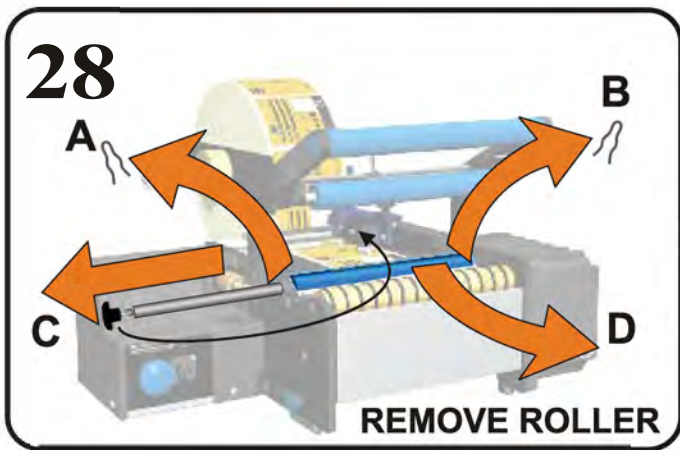

SMALL BOTTLE ADAPTOR

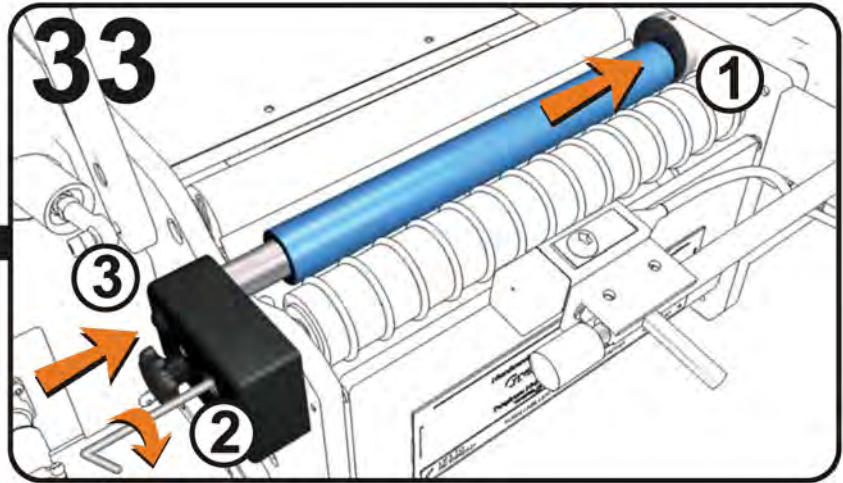
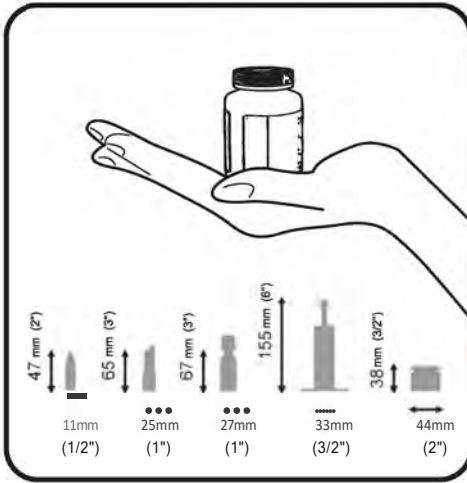
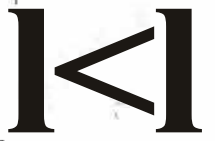

ORIENTATOR

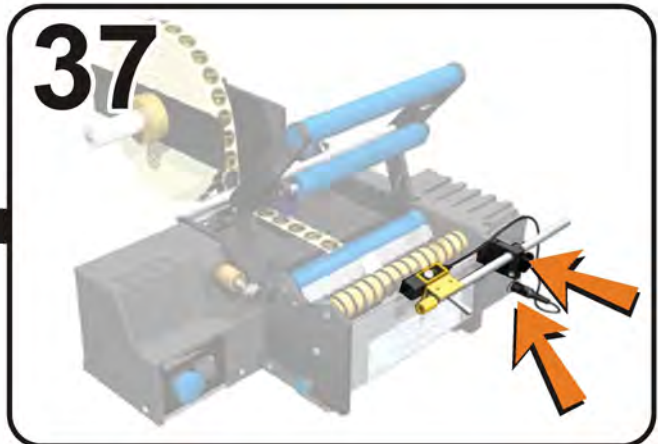
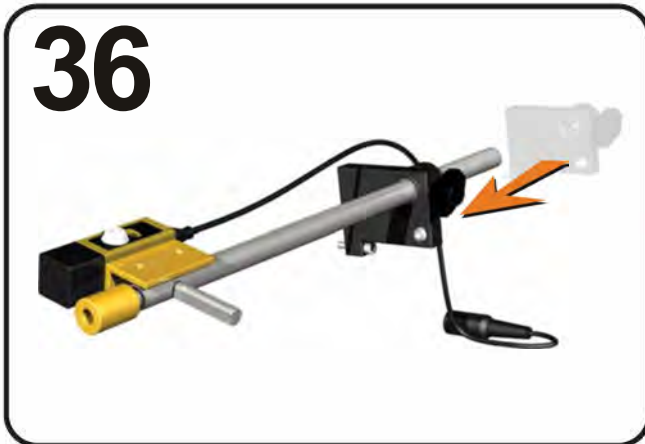
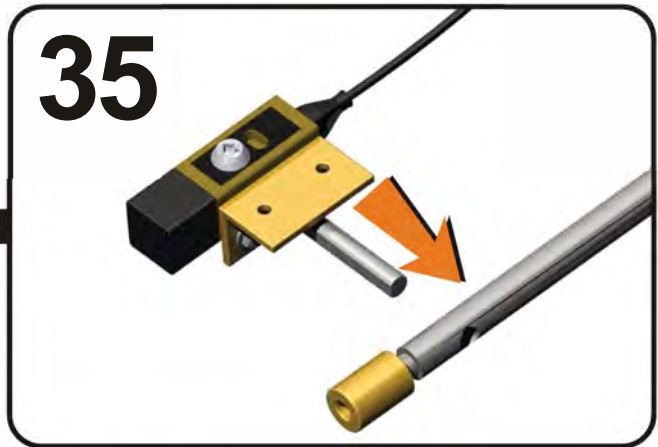

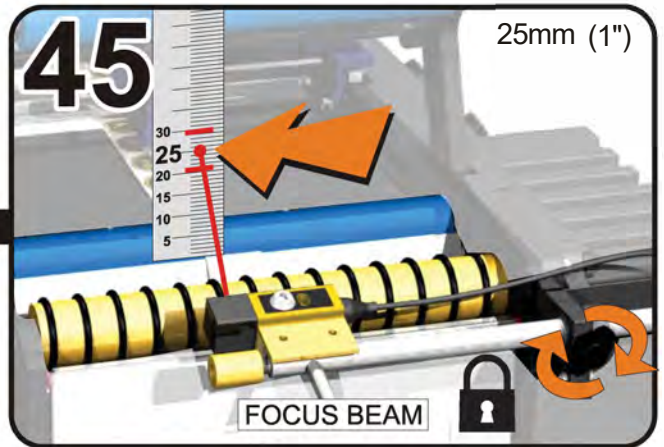
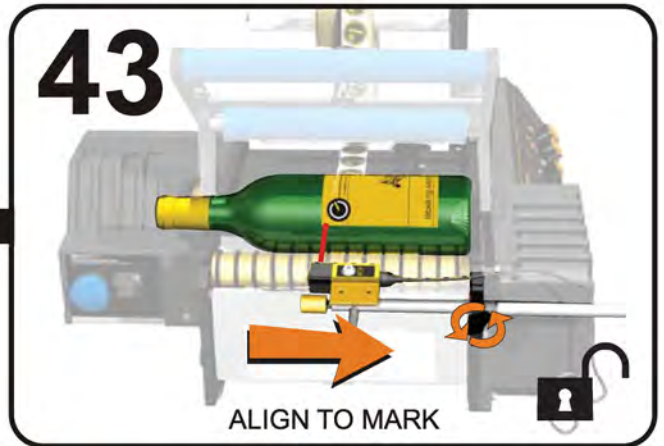
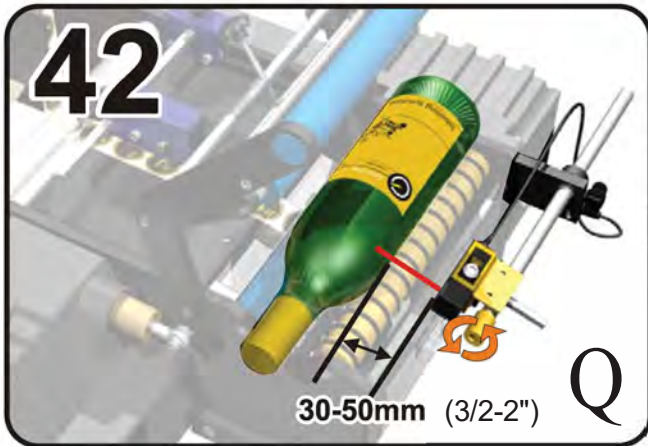
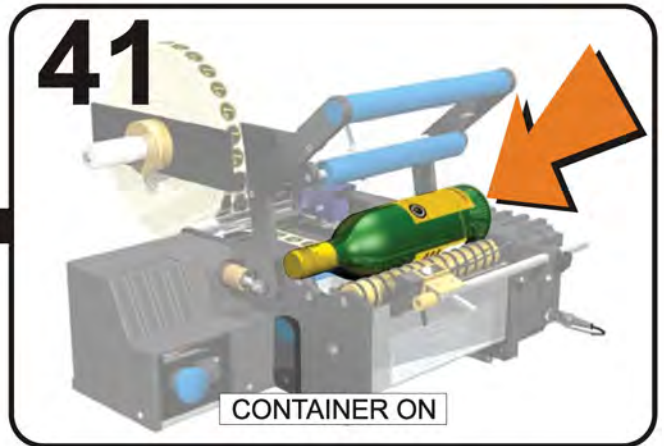
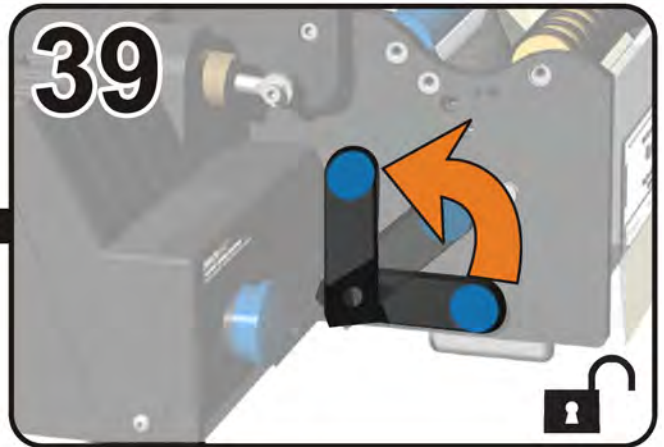
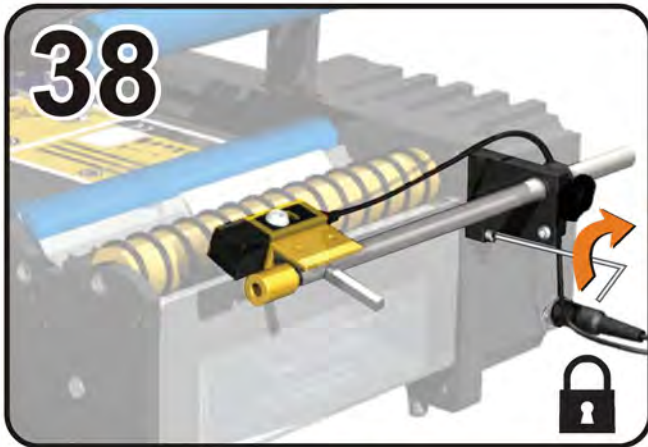

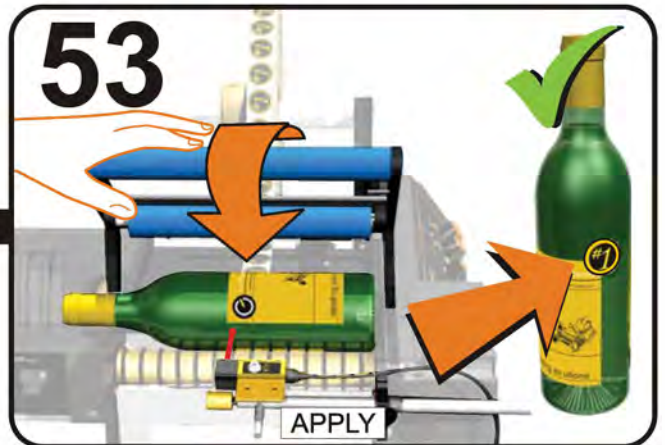
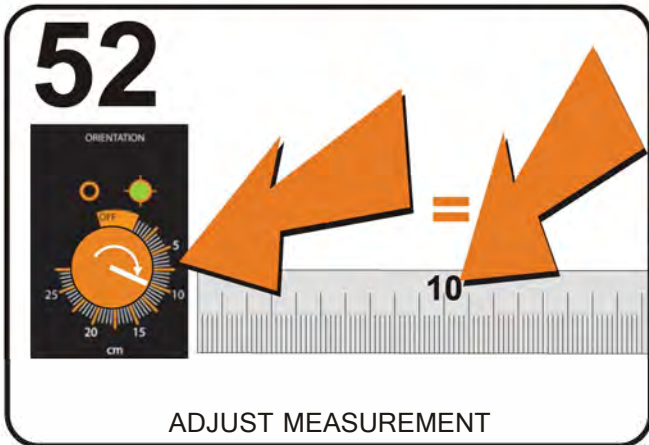
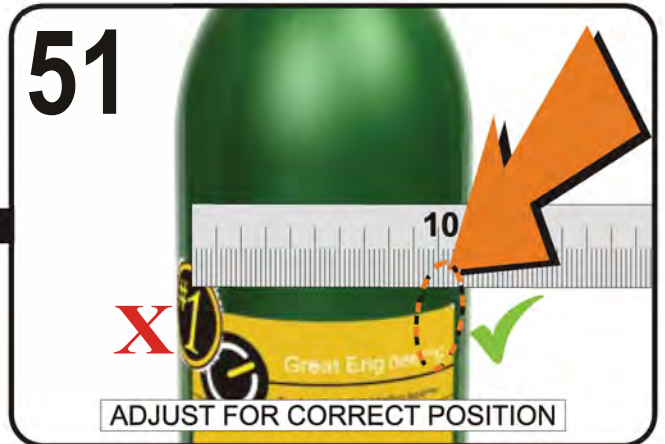
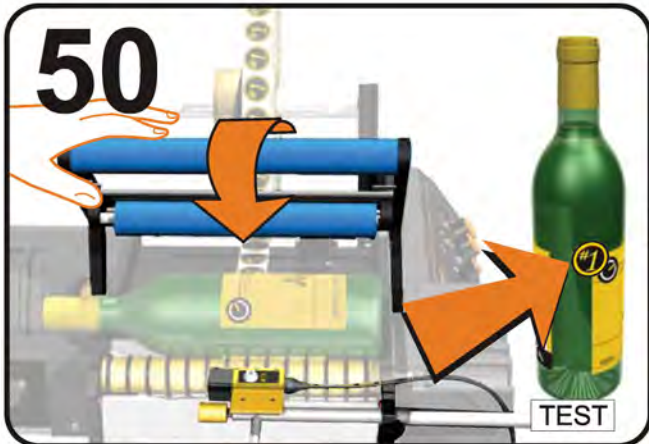
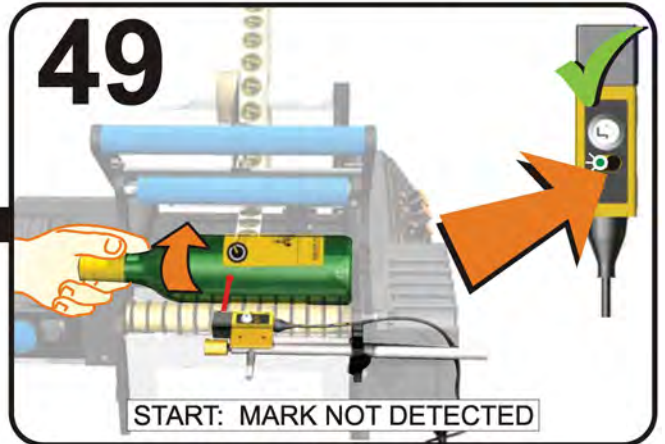
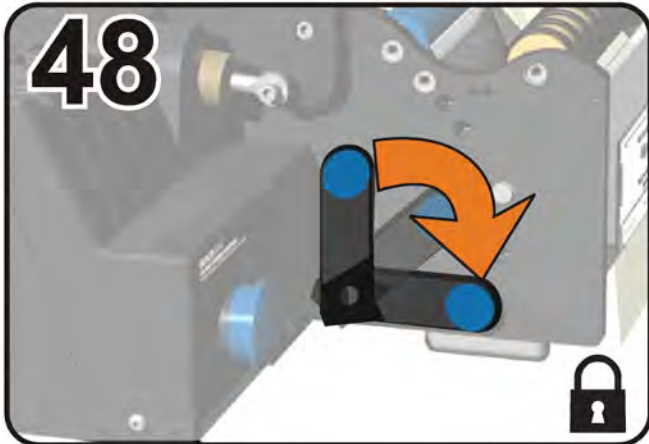
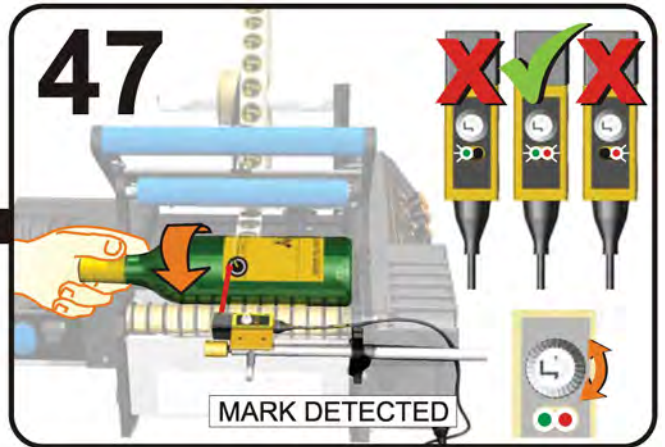
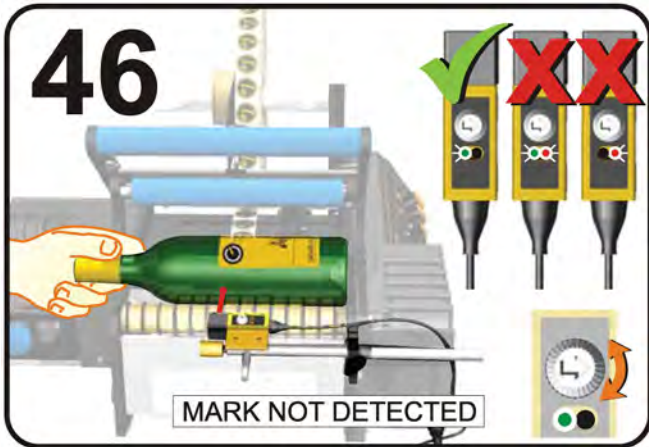

AUTOMATIC ATTACHMENT

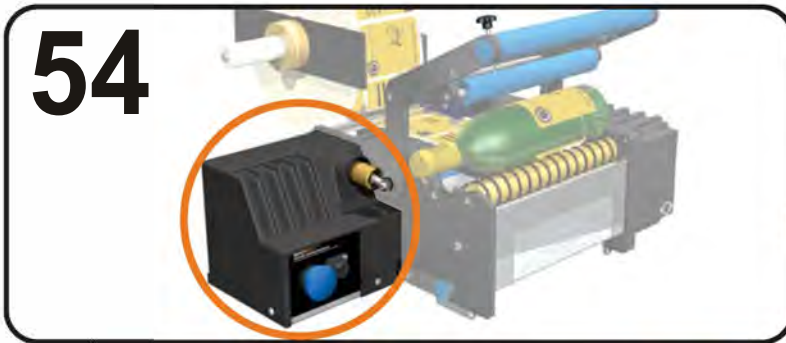

ADJUSTING PRESSURE FOR FRAGILE CONTAINERS

FOOT PEDAL



PRESS ONCE

02910

COUNTER:

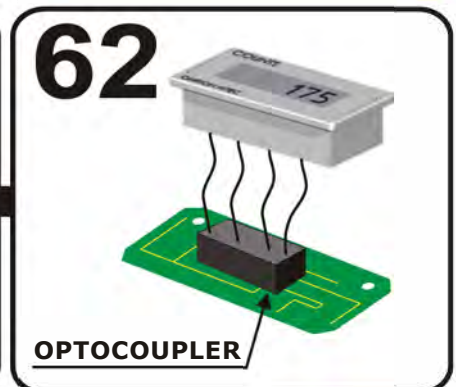
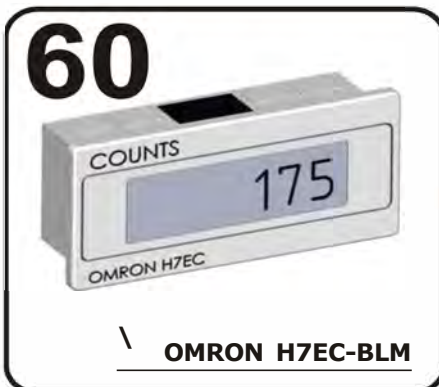



PROGRAMMING

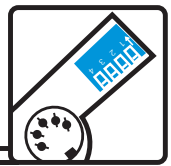

1234 Z		1234 Z		1234 Z	
ON	OFF	ON	OFF	ON	OFF
LIGHT	DARK	LONG RUB-DOWN	SHORT RUB-DOWN	230mm + (9" +)	NORMAL

PRINTERS

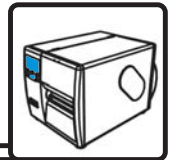

1234 Z

ON
NORMAL

PRINT

PRINTING ONLY **ONCE** PER CONTAINER

OFF

PRINTING ON **EVERY** LABEL

WIRING:

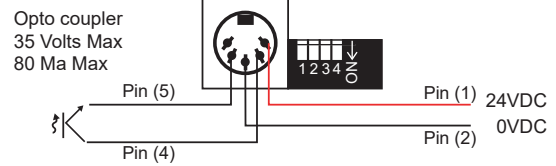

EXAMPLE.

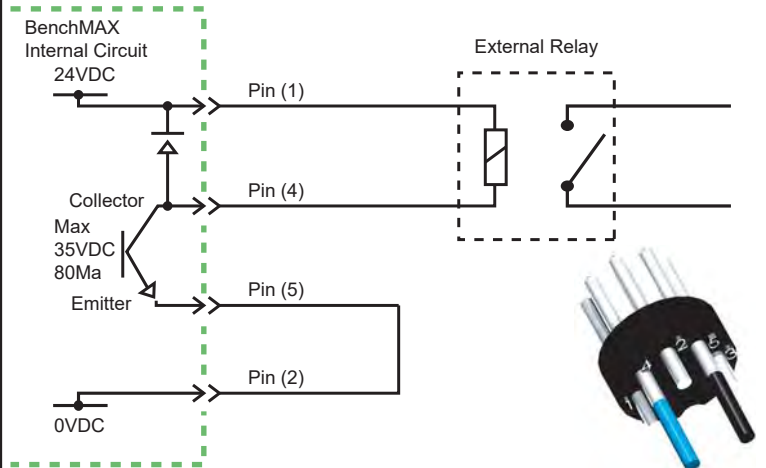

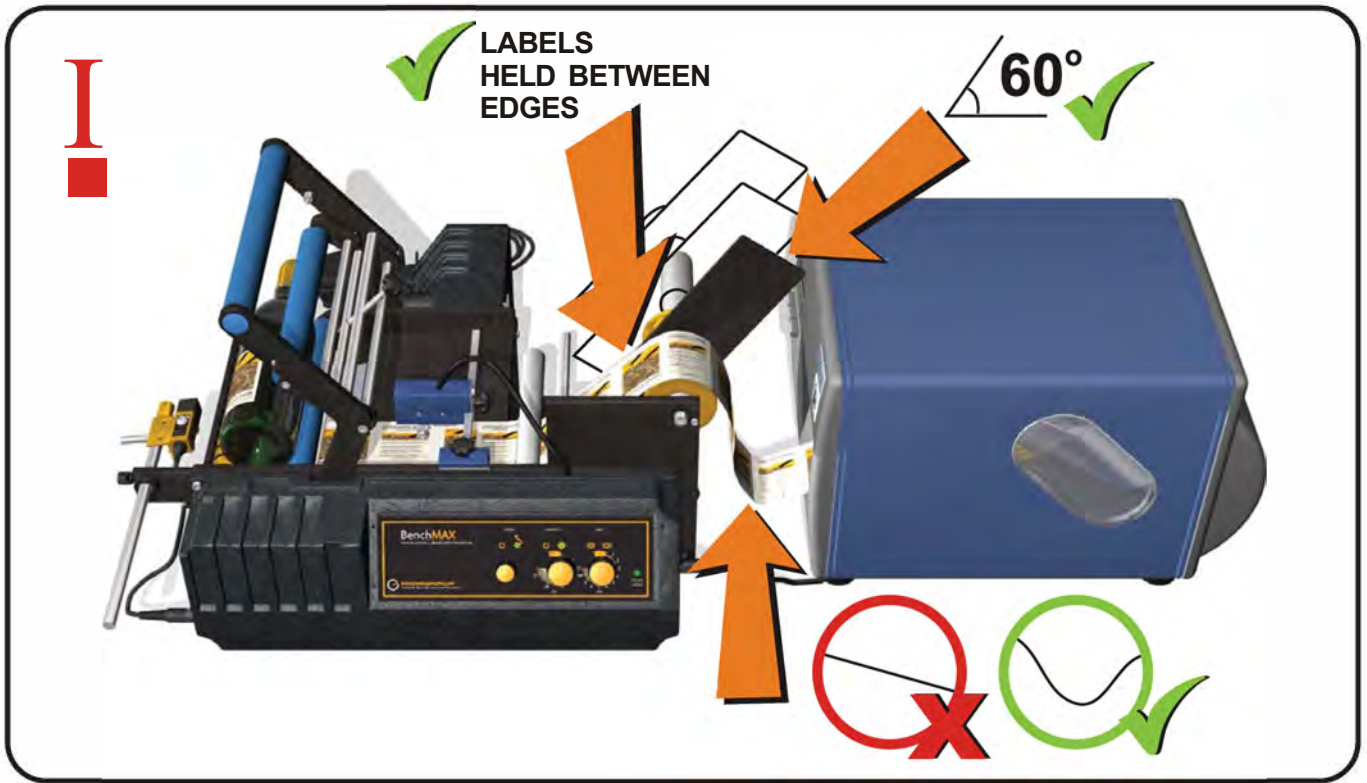
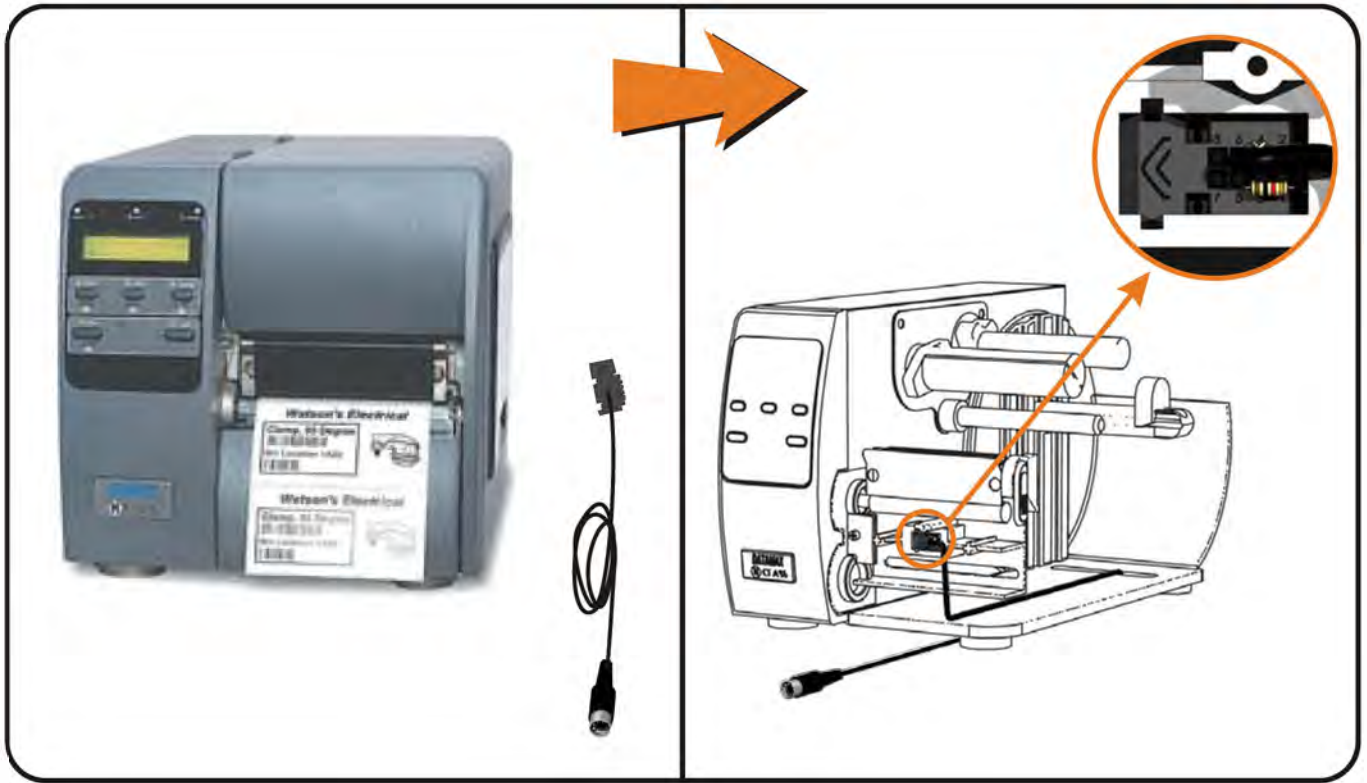



REPLACING O-RINGS, CLUTCH MAINTENANCE & REPLACING BLUE ROLLER:

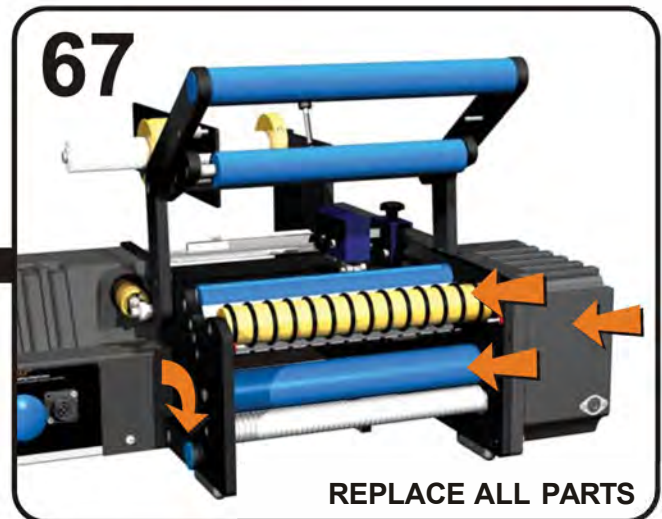
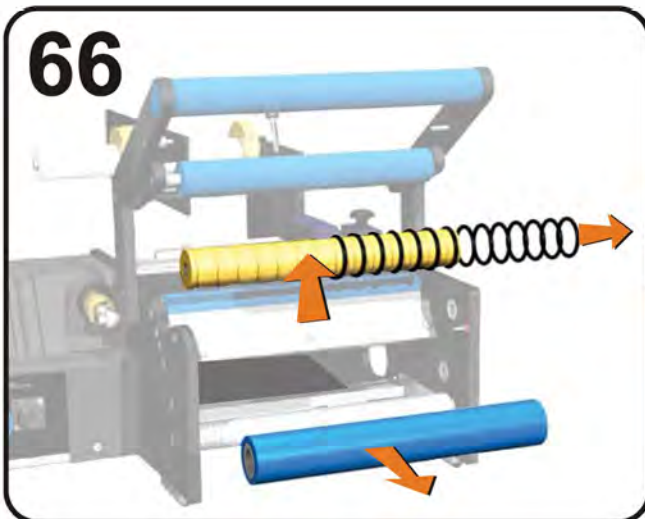
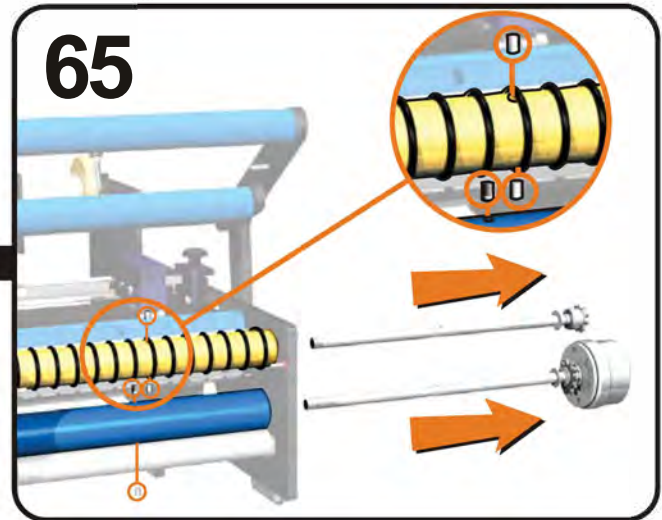



TROUBLE SHOOTING



GENERAL

!! PROBLEM !!	..(..(..(..(SOLUTION ✓✓✓✓
 <p>NO LABEL</p>	 
 <p>NOT TURNING</p>	 <p>p8: 26</p> <p>READ INSTRUCTIONS CAREFULLY</p>
 <p>NOT STRAIGHT</p>	<p>K  OR  p7: 19</p> <p>INCORRECT CONTAINER</p> <p>TIGHTEN TO ONE SIDE</p> <p>OR  p9: 28</p> <p>CHECK IF LABEL IS STUCK UNDER ROLLER</p>  <p>OR </p> <p>CHECK IF LABEL IS STUCK UNDER CURVED PLATE</p>
	 <p>p7: 20</p> <p>READ INSTRUCTIONS CAREFULLY</p>



TROUBLE SHOOTING



GENERAL











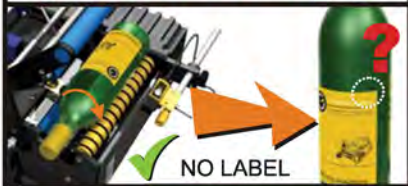

!! PROBLEM !!	..('..'('..'('..'(' SOLUTION ..('..'('..'('..'('			
	 NORMAL WHEN HANDLE RETURNS			
	 p8: 26 READ INSTRUCTIONS CAREFULLY			
		 DO NOT HOLD PEDAL DOWN		
	1	2	3	4
	 p8: 27 0 KOO READ INSTRUCTIONS CAREFULLY INCORRECT CONTAINER			
	 p6: 16 TRY THESE ADJUSTMENTS OR			



TROUBLE SHOOTING



ORIENTATOR

!! PROBLEM !!	SOLUTION
 <p>NO LABEL</p>	 p12: 46-48 OR  p11: 43 READ INSTRUCTIONS CAREFULLY
 <p>2 LABELS</p>	  
 <p>WRONG POSITION</p>	 p12: 46-47 DETECTING INCORRECT MARK  <p>SEAM?</p>
 <p>NO LABEL</p>	 p12: 48 OR  p10: 37 READ INSTRUCTIONS CAREFULLY



TROUBLE SHOOTING



AUTOMATIC ATTACHMENT

!! PROBLEM !!	SOLUTION
	 p13: 56 READ INSTRUCTIONS CAREFULLY
 <p>LOCKED & ROTATING</p>	 p8: 26 OR   <p>RESET</p>